

Sunbeam

NutriOven

Multi use convection oven

Instruction/Recipe Booklet

CO3000

Please read these instructions carefully
and retain for future reference.



Contents

Sunbeam's Safety Precautions	1
Features of your NutriOven	2
Using your NutriOven	6
Helpful Tips	6
Cooking Temperature Guide	7
Roasting Guide	8
Basic Cooking Functions	9
Care and Cleaning	10
Recipes	11
Light Meals and Snacks	11
Mains	18
Sweets	26

Important instructions – retain for future use.

تأكد من تفهم احتياطات السلامة المذكورة اعلاه

請務必理解上述的安全預防措施。

Assurez-vous que les précautions ci-dessus relatives à la sécurité sont bien comprises

Versichern Sie sich, dass die obenstehenden Sicherheitsmaßnahmen verstanden werden

Βεβαιώνετε πως οι παραπάνω προφυλάξεις ασφαλείας γίνονται κατανοητές

Pastikan bahwa tindakan-tindakan keselamatan seperti di atas dimengerti anda

Accertatevi che le suddette norme di sicurezza siano comprese a dovere

上記の注意事項をよくお読みになり、安全を御確認ください

Уверете се дека погоре споменатите мерки на претпазливост се добро разбрани

Asegúrese de que las precauciones de seguridad precedentes sean bien comprendidas

کاری بکنید کہ احتیاط‌های بالا حتماً درک بشوند

ต้องแน่ใจว่า ข้อควรระวังเรื่องความปลอดภัยข้างต้น เป็นที่เข้าใจกันดี

Yukarda belirtilen güvenlik önlemlerinin anlaşılığundan emin olunuz

Xin kiểm chắc rằng những biện pháp làm an toàn kể trên được hiểu rõ

Sunbeam's Safety Precautions

SAFETY PRECAUTIONS FOR YOUR SUNBEAM HEALTH CONVECTION OVEN.

- Always operate on a flat surface
- Avoid contact with the lid and glass bowl surfaces during and after use, as they will be hot.
- Do not touch the element or fan during use as it will be very hot
- Use well away from walls and curtains.

Sunbeam is very safety conscious when designing and manufacturing consumer products, but it is essential that the product user also exercise care when using an electrical appliance. Listed below are precautions which are essential for the safe use of an electrical appliance:

- Read carefully and save all the instructions provided with an appliance.
- Always turn the power off at the power outlet before you insert or remove a plug. Remove by grasping the plug - do not pull on the cord.
- Turn the power off and remove the plug when the appliance is not in use and before cleaning.
- Do not use your appliance with an extension cord unless this cord has been checked and tested by a qualified technician or service person.
- Always use your appliance from a power outlet of the voltage (A.C. only) marked on the appliance.
- This appliance is not intended for use by persons (including children) with reduced physical, sensory or mental capabilities, or lack of experience and knowledge, unless they have been given supervision or instruction concerning use of the appliance by a person responsible for their safety.
- Children should be supervised to ensure that they do not play with the appliance.
- The temperature of accessible surfaces may be high when the appliance is operating.
- Never leave an appliance unattended while in use.
- Do not place any items on top of the oven whilst in use
- Do not block or cover the air vents on the top, back or sides of the oven
- Do not use in confined spaces.
- Do not immerse the unit in water or any other liquid.
- Ensure that the cord is kept well away from the element during use.
- Do not use an appliance for any purpose other than its intended use.
- Do not place an appliance on or near a hot gas flame, electric element or on a heated oven.
- Do not place on top of any other appliance.
- Do not let the power cord of an appliance hang over the edge of a table or bench top or touch any hot surface.
- Do not operate any electrical appliance with a damaged cord or after the appliance has been damaged in any manner. If damage is suspected, return the appliance to the nearest Sunbeam Appointed Service Centre for examination, repair or adjustment.
- For additional protection, Sunbeam recommend the use of a residual current device (RCD) with a tripping current not exceeding 30mA in the electrical circuit supplying power to your appliances.
- Do not immerse the appliance in water or any other liquid unless recommended.
- Appliances are not intended to be operated by means of an external timer or separate remote control system.
- This appliance is intended to be used in household and similar applications such as: staff kitchen areas in shops, offices and other working environments; farm houses; by clients in hotels, motels and other residential type environments; bed and breakfast type environments.

If you have any concerns regarding the performance and use of your appliance, please visit www.sunbeam.com.au or contact the Sunbeam Consumer Service Line.

Ensure the above safety precautions are understood.

Features of your Sunbeam CO3000 NutriOven

Temperature Control

Variable temperature control allows you to select the perfect temperature for each cooking task.

Lid

The lid contains the heating element and the fan so it will become extremely hot during use. Always remove lid using the handle and always place the hot lid correctly on the lid stand. Never place the hot lid on the benchtop.

Glass Bowl

Tempered glass bowl is dishwasher safe. Easily removable from the base stand.

Base Stand

The glass bowl and the lid can become extremely hot during use. Always move the oven using the base stand handles. Keep hands and fingers from touching the hot glass bowl during carrying.

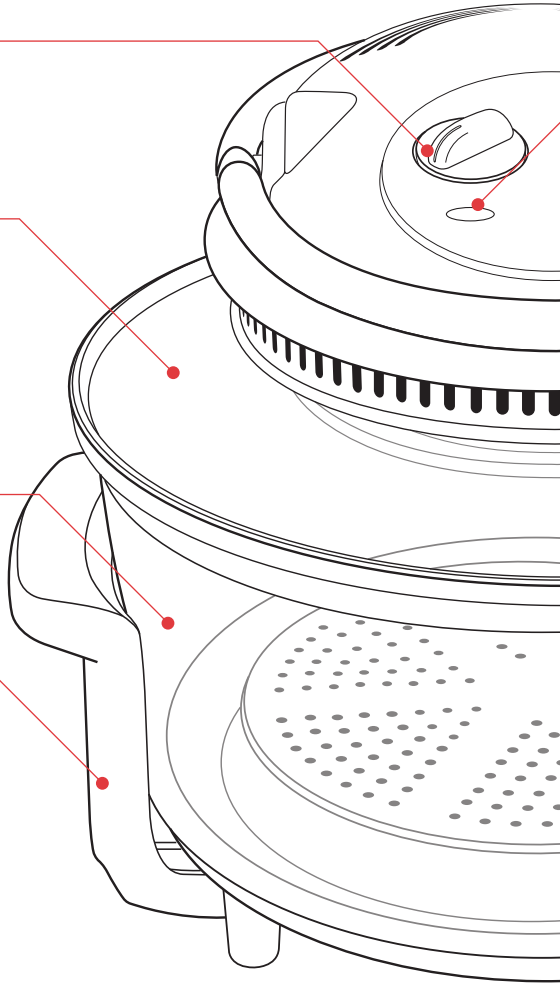

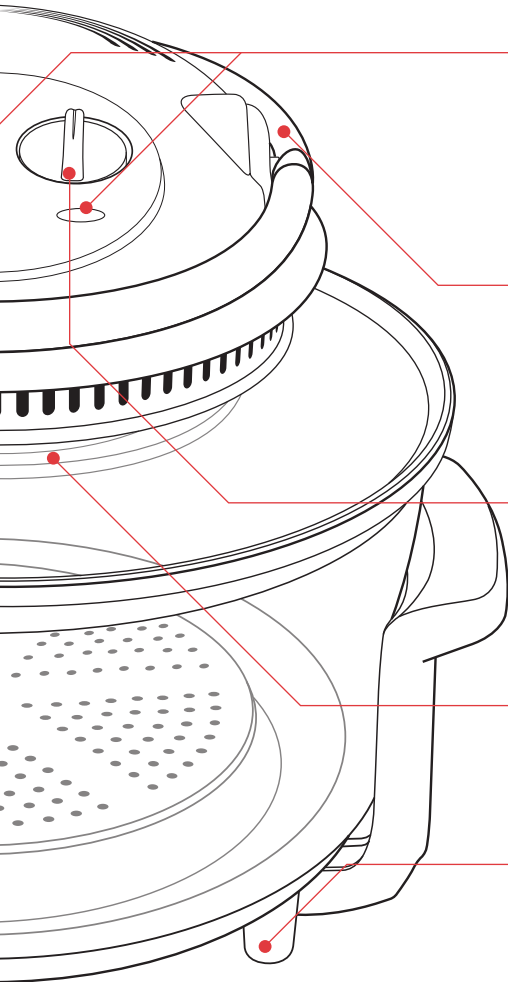

Power and Warm Up Lights

The Power light indicates when the oven is turned on. Note that if the Power Safety Handle is raised the Power will not be on. The Warm Up light Indicates when the oven is heating up.

Power Safety Handle

When the handle is in the down position, the oven is ready for use. When the handle is raised, the fan and the motor switch off automatically for safety. Always lift the lid by the safety handle.

Timer Control

60 minute safety timer switch. If longer cooking time is needed, the timer will need to be reset during cooking.

Element

Powerful 1200 watt element for fast heat up.

Non-slip rubber feet

Keeps the oven secure on the bench top during use and prevents scratching of bench top surfaces.

Features of your Sunbeam NutriOven continued

High Rack

The high or the low rack should always be used, even if used with another accessory. Can be used by itself or with the low rack for dual level cooking. Food cooked on the high rack cooks the fastest. Suitable for Grilling, Toasting and Dry Frying.

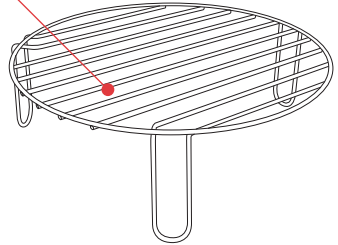

Low Rack

The high or the low rack should always be used, even if used with another accessory. Food should not be placed directly on the bottom of the oven. The low rack allows air to circulate under the food, which is essential for efficient convection cooking, and also allows the food to sit above the fats and juices which accumulate at the bottom of the bowl. Suitable for Roasting, Steaming and Baking.

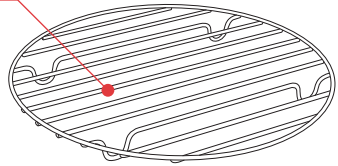

Multi-Purpose Baking Dish

Can be used to bake and dry fry small items such as scones, vegetables and chips.

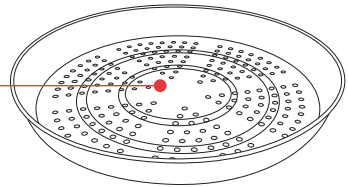

Non-stick Extension Ring

Recommended for use if cooking foods that take a period of time such as roasts or cakes. This prevents over browning before the food is cooked through. Can also be used to gain height in the oven when cooking larger items such as roasts. Using the extension ring can increase cooking times.

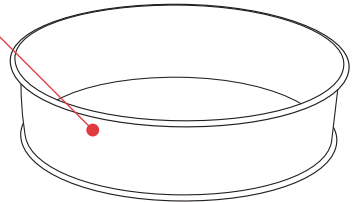

Features of your Sunbeam NutriOven continued

Oven Tongs

Use the oven tongs to lift racks and pans into and out of the oven. It's best to place food on the racks and pans outside of the oven, then use the oven tongs to lift into the oven for cooking. The oven tongs are not to be used to lift food.

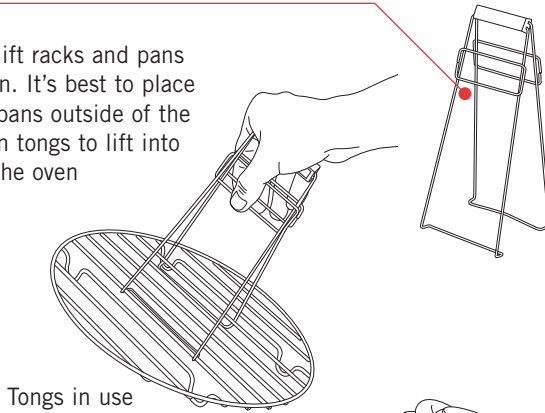

Lid Holder

The lid contains the element and the fan so it is very hot. Never place the lid directly onto any benchtop or other surface. Always place the lid into the lid holder as per the photograph. Ensure the electrical cord is facing down towards the bench top. Do not use the electrical cord to lift the lid.

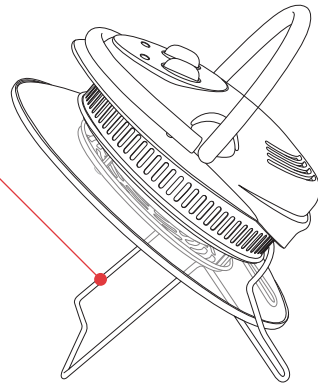

Using your NutriOven

Position the oven on a dry, level surface ensuring the ventilation slots on the lid are not obstructed. Plug the power cord into a 230-240 volt power outlet and turn the power on.

Preheat to 250°C. This compensates for the heat lost when removing the lid and placing food in the oven. Outside the oven, arrange food on the appropriate racks and/or pans.

Remove the lid. Using the oven tongs lower the racks and/or pans into the oven. Set the temperature and the timer as required.

When cooking has completed, turn off the temperature and the timer. Remove the lid and place in the lid holder. As the lid will still be hot, move to an area that is away from your food preparation and plating up area. Use the oven tongs to remove the racks and pans from the oven.

Similar to a built-in oven in your kitchen, you will need to become familiar with your NutriOven and adjust cooking times and temperatures according to your requirement.

Helpful Tips

- Overloading the oven will slow down the cooking process.
- Food will take slightly longer to cook if the oven is in a very cold environment
- Placing vegetables in a bowl and covering with boiling water for 5 minutes will assist the cooking process.
- Always pre-heat oven to 250°C – this compensates for the heat lost while removing lid and placing food in the oven.
- Work quickly to minimise heat loss. Before removing the lid, ensure you are prepared and have everything you need close by
- Where possible, place food directly onto the wire racks to allow air to circulate freely.
- Where possible, arrange food on the racks outside the oven before removing the lid.
- Always use the oven tongs provided to add or remove wire racks, baking dish, trays etc
- Be aware that when the timer finishes, the oven will turn off. If you are cooking food for longer than 1 hour, we recommend that you keep an eye on the timer and increase the timer during cooking.
- It is important to cook mince meat, sausages and poultry until well done. No pink should be visible and juices should run clear.
- Silicone bakeware is not suitable to use in the NutriOven.
- Oven bags are not suitable to use in the NutriOven.

Cooking Temperature Guide

Use these cooking times as a guide. Cooking times and temperatures will vary depending on factors such as weight, cut of the food and your personal taste. Similar to your built-in oven in your kitchen, you may need to adjust cooking times and temperatures to your requirements. Monitor the food as it's cooking and modify accordingly. It is important to cook mince meat, sausages and poultry until well done. No pink should be visible and juices should run clear.

Cooking Temperature Guide	
Bake	170 - 190°C
Roast	200 - 250°C
Steam	180 - 200°C
Grill	220 - 250°C
Dry Fry	220 - 250°C
Toast	220 - 250°C

Roasting Guide

A meat thermometer shows the exact temperature inside the poultry or meat. If using a meat thermometer, insert the probe into the centre of the thickest part of the food ensuring it does not contact bone, fat or gristle.

Meat/Poultry	Internal temperature of food once cooked. °C	Approximate time per 500g cooked at 200°C
Beef - Medium Rare	63	15 minutes
Beef – Medium	71	20 minutes
Beef – Well done	77	25 minutes
Lamb - Medium Rare	63	15 minutes
Lamb – Medium	71	20 minutes
Lamb – Well done	77	25 minutes
Veal - Medium Rare	63	20 minutes
Veal – Medium	71	25 minutes
Veal – Well done	77	30 minutes
Pork – Medium	71	30 minutes
Pork – Well done	77	35 minutes
Whole chicken	82	25-30 per 500g
Thighs, Wings, Legs	82	45 minutes
Breast	77	15 minutes

Basic Cooking Functions

Bakes

Bake at around 170 - 190°C. You can bake almost anything – Cakes, Scones, Biscuits, Muffins, Breads, Quiches, Frittatas, Potatoes and Fish. If baking biscuits or scones, we recommend you use the multi-purpose baking dish to allow air to circulate. For cakes, we recommend ring tins which allow cakes to cook through to the centre. If using your own baking pans or tins, and not the ones supplied with the NutriOven, check that they fit in the oven before using. Silicone bakeware is not suitable to use in the NutriOven.

Roasts

Roast at around 200 - 250°C. You can roast meats, vegetables, potatoes and wedges. We suggest lining the bottom of the bowl under the rack with aluminium foil turned up at the edges. This will catch drippings and make cleaning easier. Roasts will need to be turned at least once in the cooking cycle unless they are very small. For vegetables, it may be necessary to remove meat and let it stand whilst the vegetables finish cooking.

Note: Meat with a bone will take longer than a boneless roast. Marinated meats are best cooked using the extension ring as some marinades burn/ blacken easily. Oven bags are not suitable to use in the NutriOven.

Steams

Steam at around 180 - 200°C. Steam your favourite seafood, poultry and vegetables. When steaming, food should not be very cold. To steam vegetables, wrap wet vegetables in foil parcels with a little hot water. Secure the foil ends well, so the foil is not blown off or sucked up by the convection fan. Oven bags are also suitable instead of foil. Place the foil parcels in the oven so that the air

can circulate around them. Fish can also be steamed using foil parcels as this will allow the fish to steam in its own juices.

Note: to speed up steaming time of vegetables, soak them in hot water.

Grills

Grill at around 220 - 250°C. Grill meats, seafood, vegetables and your favourite cheese topping. For grilling, the oven needs to be very hot for fast cooking and the food must not be too cold. Using cold food for grilling and for any of the other cooking functions, can extend cooking times.

Note: you will not achieve the same amount of browning as you would on a bbq or in a frypan. A small amount of oil sprayed or wiped onto the food will help in browning.

Dry Frys

Dry fry at around 220 - 250°C. Dry fry bacon, sausages, eggs, vegetables, chips and more. Once cooked, do not allow the food to stand in the oven as the steam may cause the food to soften. A small amount of oil sprayed or wiped onto the food will help in browning and crisping.

Toasts

Toast at around 220 - 250°C. Toast sweet and savoury breads, pastries, rolls and sandwiches. You can also toast cheese melts and pizzas.

Care and Cleaning

- The NutriOven is incredibly easy to clean.
 - Always turn the power off and remove the plug from power outlet after use and before cleaning.
 - Allow the tempered glass bowl and accessories to cool down before cleaning.
 - It is important to clean the oven after each use for good food safety hygiene and to prevent a build up of grease or residue and to prevent unpleasant odours.
 - Never place the lid element down on the bench surface. Use the Lid Holder to brace the lid during use. Be careful not to place the lid on the electrical lead.
 - Do not touch the element
 - The tempered glass bowl is dishwasher safe.
 - The glass bowl is not suitable for the fridge, freezer or oven.
 - The tempered glass bowl can be washed in the unit itself. Fill up the glass bowl with approximately 80mm of hot water and add mild dishwashing detergent. Replace the lid, push the power safety handle down and set the timer for 10-15 minutes. Set the temperature to 150 degrees. At the conclusion, if there is any excess residue remove with a dishwashing brush and rinse with warm water to remove the soap residue and food remnants.
 - Never leave water in the bowl after washing is completed, as the condensation can build up and cause damage to the element and fan.
 - The tempered glass bowl, wire racks, multi-purpose baking pan, drip tray, and crumb tray, may be washed in warm soapy water and rinsed.
 - The lid of the oven can be wiped with a mild detergent and a damp cloth.
- Note:** Do not clean the lid of the oven in the dishwasher. Never immerse the lid of the oven in water.

Light Meals and Snacks

Cheesy Corn Muffins

Makes 6

- 1 cup self-raising flour
- ¼ cup grated cheddar cheese
- 125g can corn kernels, drained
- 2 green shallots, thinly sliced
- ½ cup milk
- 1 egg
- 40g butter, melted
- 2 teaspoons polenta
- 2 tablespoons extra grated cheddar cheese

 1. With the Extension ring and High Rack in place, preheat oven to 250°C. Lightly grease a 6-hole muffin pan.
 2. Place flour, cheese, corn, shallots and butter in a bowl.
 3. Whisk the milk and egg in a jug. Add to the flour mixture and stir until just combined.
 4. Divide mixture into prepared pan. Sprinkle with polenta and extra cheese.
 5. Using the Oven Tongs, lower the pan into the oven. Reduce temperature to 180°C.
 6. Bake for 25 minutes or until just cooked. Remove immediately from pan and cool on a wire rack.

Cheese and Spinach Parcels

Makes 12 (approximately)

- 1 packet frozen spinach, thawed
- 2 eggs
- 300g fresh ricotta
- 100g feta, crumbled
- Filo pastry
- Cooking oil spray

 1. With the Extension ring in place, preheat oven to 250°C.
 2. Drain spinach and use your hands to squeeze out as much water as possible. Place in a large bowl. Mix through egg and season with pepper. Stir through ricotta and feta.
 3. Place one sheet of filo pastry on the bench and spray with cooking oil spray; fold lengthways into thirds. Place 2 tablespoons of mixture in one corner. Fold pastry diagonally across to form a triangle that encloses spinach mixture. Continue folding pastry diagonally, retaining the triangle shape. Repeat with remaining pastry and spinach mixture.
 4. Outside the oven, arrange triangles, seam side down, on the Low and High Rack; spray with cooking oil spray. Using the Oven Tongs, lower the racks into the oven. Reduce oven to 200°C.
 5. Cook for about 25 minutes or until golden.

Tip: Don't be tempted to overfill the triangles or they will burst.

Light Meals and Snacks continued

Stuffed Mushrooms

Serves 3 (as a starter)

½ cup fresh breadcrumbs

2 shortcut bacon rashers

20g melted butter

1 tablespoon chopped fresh herbs (such as thyme, parsley and rosemary)

2 tablespoons ricotta

12 (300g) small cup mushrooms

Rocket salad, to serve

1. With the Low Rack in place, preheat oven to 250°C.
2. Place breadcrumbs and bacon in the Multi-purpose baking dish. Using the Oven Tongs, lower the dish into the oven. Cook for about 5 minutes or until breadcrumbs are golden; using the Oven Tongs, remove dish from oven. Finely chop bacon.
3. Place breadcrumbs, bacon, butter, herbs and ricotta in a bowl. Mix to combine; season with salt and pepper.
4. Twist and pull stems from mushrooms; discard stems. Using a small spoon, scoop slightly to neaten the hole in the mushroom cap.
5. Using a small spoon, press the breadcrumb mixture into the mushroom cavity. Outside the oven, arrange mushrooms onto the High Rack. Using the Oven Tongs, lower the rack into the oven.
6. Reduce temperature to 200°C. Cook for 10 minutes or until mushrooms are just tender. Serve with rocket salad.

Kumara Chips

Serves 4 (as a side dish)

250g thinly sliced kumara

Cooking oil spray

1. Preheat oven to 250°C.
2. Outside the oven, arrange sliced kumara on the high and Low Racks. Spray with cooking oil spray.
3. Using the Oven Tongs, lower the racks into the oven. Cook for 5-10 minutes or until crisp and beginning to curl.

Tip: Use a V-Slice or mandoline to slice Kumara. Very thin slices will assist them to curl and crisp.

Light Meals and Snacks continued

Kumara and Ricotta Pizza Snacks

Serves 2

200g kumara, sliced

Cooking oil spray

2 regular tortillas

1 ½ tablespoons tomato paste

1 tablespoon chopped fresh sage

¼ cup grated tasty cheese

50g Ricotta, crumbled

1. Preheat oven to 250°C.
2. Outside the oven, arrange sliced kumara on the high and Low Racks. Spray with cooking oil spray.
3. Using the Oven Tongs, lower the racks into the oven. Cook for 5 minutes or until tender.
4. Remove racks from oven. Place kumara onto a plate.
5. Spread tortillas with tomato paste and place one on each rack. Sprinkle with sage and grated cheese; top with kumara slices. Using the Oven Tongs, lower racks into the oven. Cook for 5 minutes or until base is beginning to crisp and cheese has melted. Using the Oven Tongs, remove racks from oven. Slide pizza snacks onto a chopping board and sprinkle with ricotta. Cut into wedges to serve.

Potato Wedges

Serves 4 (as a side dish)

800g large potatoes, washed, cut into wedges

1 tablespoon olive oil

½ teaspoon paprika

Salt, to taste

Sour cream and sweet chilli sauce, to serve

1. Preheat oven to 250°C.
2. Place potatoes, oil, paprika and salt in a bowl; toss to coat. Outside the oven, arrange the wedges onto the high and Low Racks.
3. Using the Oven Tongs, lower the racks into the oven. Cook for about 30 minutes or until crisp and golden.
4. Serve with sour cream and sweet chilli sauce.

Light Meals and Snacks continued

Roast Beetroot Salad

Serves 4 (as a side dish)

1 bunch beetroot, trimmed

1 ½ tablespoons olive oil

1 ½ tablespoons white wine vinegar

½ teaspoon Dijon mustard

100g baby spinach

1 small red onion, thinly sliced

100g fetta, crumbled

1. With the Extension ring and Low Rack in place, preheat oven to 250°C.
2. Peel the beetroot using a vegetable peeler and cut into wedges. Arrange beetroot in the Multi-purpose baking dish. Using the Oven Tongs lower the dish into the oven. Reduce the temperature to 200°C. Cook for about 30 minutes or until tender.
3. To make dressing, whisk the oil, vinegar and mustard together in a small jug.
4. Arrange the baby spinach and onion on a serving platter. Top with beetroot and fetta. Drizzle with dressing just before serving.

Tip: Use gloves when handling beetroot or they will stain your hands.

Big Breakie

Serves 4

4 thin sausages

4 shortcut bacon rashers

4 eggs

Cooking oil spray

2 roma tomatoes, halved

4 small slices white bread

1. With the Low Rack in place, preheat the oven to 250°C.
2. Outside the oven, arrange sausages and bacon on the High Rack. Using the Oven Tongs, lower the High Rack into the oven. Cook for about 10 minutes or until sausages have cooked through. Using the Oven Tongs, remove High Rack from the oven. Place sausages and bacon onto a plate and cover to keep warm.
3. Lightly grease 4 individual oven-proof ramekins. Crack an egg into each ramekin and lightly spray surface with cooking oil spray. Outside the oven, arrange bread on the High Rack. Place ramekins and tomatoes into the oven on the Low Rack. Using the Oven Tongs, lower the High Rack into the oven.
4. Cook for 5 minutes or until toast is golden and eggs are cooked as desired. Serve eggs, tomatoes and toast, with sausages and bacon.

Light Meals and Snacks continued

Bacon and Egg English Muffins

Serves 4

2 eggs

Cooking oil spray

2 shortcut bacon rashers

2 english muffins, halved

2 slices tasty cheese

Barbecue sauce to serve

1. With the Low Rack in place, preheat oven to 250°C.
2. Lightly grease 2 individual oven-proof ramekins. Crack an egg into each ramekin and lightly spray surface with cooking oil spray. Outside the oven, arrange bacon and muffins on the High Rack.
3. Place ramekins in the oven on Low Rack. Using the Oven Tongs, lower the High Rack into the oven. Cook for 5 minutes or until bacon is crisp and muffins are toasted. Remove High Rack and eggs from oven. Remove eggs from ramekin and place on one half of each muffin. Top with bacon and cheese; return to High Rack. Using the Oven Tongs, lower the High Rack into the oven and grill until cheese melts.
4. Serve with barbecue sauce and top with remaining half of muffin.

Chicken and Avocado Turkish Melt

Serves 2

2 x 200g chicken breast

Cooking oil spray

Salt and pepper, to taste

2 Turkish bread rolls, halved

1 tomato, thinly sliced

½ avocado, thinly sliced

2 slices tasty cheese

Sweet chilli sauce and rocket leaves, to serve

1. With the Low Rack in place, preheat oven to 250°C.
2. Lightly spray chicken breast with cooking oil spray. Season with salt and pepper.
3. Place chicken in the oven on the Low Rack. Cook for about 10 minutes.
4. Outside the oven, arrange the 2 bottom halves of Turkish rolls on the High Rack. Using the Oven Tongs, lower the High Rack into the oven. Cook for about 5 minutes or until chicken is cooked through and bread is toasted. Using the Oven Tongs, remove high and Low Racks from oven; slice chicken
5. Outside the oven, arrange remaining Turkish roll tops on High Rack and place in the oven for 3 minutes or until toasted.
6. Meanwhile, place chicken on toasted Turkish roll bottoms; top with tomato, avocado and cheese. Return to High Rack and grill for 2 minutes or until cheese has melted.
7. Serve topped with sweet chilli sauce, rocket and Turkish roll tops.

Light Meals and Snacks continued

Oysters Kilpatrick

Serves 2 (as a starter)

3 bacon rashers

12 oysters on the half shell

1 teaspoon Worcestershire sauce

1. Preheat oven to 250°C.
2. Outside the oven, arrange bacon on High Rack. Using the Oven Tongs, lower the High Rack into the oven. Grill for about 5 minutes or until crisp. Remove bacon from oven, leaving the high rack in place. Trim fat from bacon; discard. Finely chop trimmed bacon.
3. Outside the oven, place the oysters in the Multi-purpose baking dish. Drizzle with Worcestershire sauce and top with bacon. Using the oven tongs, lower the dish into the oven. Cook for a further 2 minutes or until warm.

Mains

Steamed Asian Fish Parcels

Serves 2

2 x 400g snapper

1 lemon, thinly sliced

1 clove garlic, thinly sliced

1cm piece fresh ginger, thinly sliced

2 teaspoons peanut oil

2 teaspoons soy sauce

1 long red chilli, thinly sliced

2 green shallots, thinly sliced

¼ cup coriander leaves

Steamed rice, to serve

1. With the Extension ring in place, preheat oven to 250°C.
2. Rinse the fish cavity under running water and pat dry with absorbent paper towel.
3. Score fish three times on each side. Place a piece of foil on the bench, large enough to enclose fish. Lay a piece of baking paper on top of foil. Place 1 fish onto baking paper. Repeat with remaining fish.
4. Fill fish cavity with slices of lemon, garlic and ginger. Drizzle with oil and soy sauce. Gather corners of foil above fish and twist to securely enclose.
5. Outside the oven, place fish parcels on the High Rack. Using the Oven Tongs, place the High Rack into the oven. Reduce temperature to 200°C. Cook for about 25 minutes or until cooked through.
6. To serve, open parcels and top with chilli, shallots and coriander.

Tip: Fish is cooked with the flesh turns white and flakes easily.

Roast Chicken

Serves 4

1.4kg whole chicken

2 tablespoons olive oil

Salt and pepper, to taste

1. With the Low Rack in place, preheat oven to 250°C.
2. Remove excess fat from chicken and rinse out cavity. Pat dry inside and out with absorbent paper towel.
3. Rub oil over chicken skin. Rub salt and pepper all over chicken. Place chicken on the Low Rack, breast side down. Reduce temperature to 200°C.
4. Roast for 1 hour 10 minutes or until cooked through, turning chicken halfway through cooking.

Tandoori Chicken Wings

Serves 4

¼ cup tandoori paste

125g tub natural yoghurt

1kg chicken wings

Lemon wedges and coriander leaves, to serve

1. Preheat oven to 250°C.
2. Place tandoori paste and yoghurt in a large bowl; mix to combine. Add chicken wings and toss to coat thoroughly.
3. Outside the oven, place chicken wings on the Low Rack. Using the Oven Tongs, lower the rack into the oven. Cook for 30 minutes or until cooked through, turning halfway through cooking.
4. Serve with lemon wedges and sprinkle with coriander.

Mains continued

Chorizo and Vegetable Frittata

Serves 4-6

300g kumara, peeled, cut into 1cm pieces

1 small red onion, thinly sliced

1 chorizo (100g), halved lengthways

8 eggs

½ cup cream

½ cup grated parmesan

½ cup frozen peas and corn, thawed

¼ cup chopped parsley

Salad, to serve

1. With the Extension ring and Low Rack in place, preheat oven to 250°C. Grease and line the base of a 22cm round cake pan. Lightly grease the Multi-purpose baking dish.
2. Place kumara and onion in a bowl and cover with boiling water. Stand for 5 minutes; drain vegetables and place in the prepared Multi-purpose baking dish.
3. Outside the oven, place the chorizo on the High Rack. Using the Oven Tongs, place the baking dish on the Low Rack and lower the High Rack into the oven. Cook for about 10 minutes or until chorizo is cooked. Remove the chorizo and vegetables from the oven; thinly slice the chorizo.
4. Place eggs, cream and cheese in a bowl. Season with salt and pepper and whisk to combine. Add sliced chorizo, kumara, onion and remaining ingredients. Mix to combine. Pour egg mixture into prepared cake pan.
5. Reduce temperature to 180°C and cook for about 1 hour 10 minutes or until set. Remove from oven; stand for 10 minutes before serving with salad.

Pork Ribs with Barbecue Sauce

Serves 2

2 small racks (750g) pork spare ribs

½ cup barbecue sauce

½ cup tomato sauce

⅓ cup sweet chilli sauce

⅓ cup brown sugar

2 tablespoons dijon mustard

Wedges and salad, to serve

1. With the Extension ring in place, preheat oven to 250°C.
2. Cook the spare ribs in a large saucepan of boiling water for 10 minutes; drain.
3. Combine sauces, sugar and mustard in a large bowl. Add ribs and toss to coat well in mixture.
4. Outside the oven, place ribs in on the High Rack. Using the oven tongs, lower the rack into the oven. Reduce temperature to 220°C and cook for 30 minutes or until caramelised and tender. Serve with wedges and salad.

Mains continued

Lemon and Herb Chicken

Serves 6

- 1 tablespoon chopped thyme
- 1 tablespoon chopped rosemary
- 1 tablespoon finely grated lemon rind
- 1 tablespoon lemon juice
- ¼ cup olive oil
- Salt and pepper, to taste
- 1.5kg chicken pieces
- 1. Preheat oven to 250°C.
- 2. Combine herbs, lemon rind, juice, oil and salt and pepper in a large bowl. Add chicken pieces and toss to coat.
- 3. Outside the oven, arrange chicken on the low and High Rack. Using the Oven Tongs, lower the racks into the oven.
- 4. Cook for 45 minutes or until chicken is golden and cooked through.

Salt and Chilli Prawn Skewer

Makes 8 skewers

- 1 tablespoon finely grated lemon rind
 - 1 teaspoon dried chilli flakes
 - 1 teaspoon sea salt flakes
 - 1 tablespoon olive oil
 - 500g green peeled prawns, tails in tact
 - 1. Preheat oven to 250°C.
 - 2. Combine lemon rind, chilli, salt and oil in a medium bowl. Add prawns and toss to coat.
 - 3. Thread prawns onto 8 wooden skewers. Outside the oven, arrange prawn skewers on the low and High Rack. Using the Oven Tongs, lower the racks into the oven.
 - 4. Cook for 5 minutes or until prawns are cooked. Serve with lemon aioli for dipping.
- Tip:** Prawns change from green to vibrant orange when cooked. Don't over cook the prawns or they will go rubbery.

Lemon Aioli: In a small bowl combine 1/3 cup whole egg mayonnaise, 1 clove crushed garlic and 1 tablespoon lemon juice. Season with salt and pepper.

Mains continued

Roast Vegetable Pasta Salad

Serves 6

- 1 eggplant, cut into 1cm rounds
- 250g punnet mini roma tomatoes
- 100g button mushrooms, quartered
- 1 yellow capsicum, chopped
- 350g penne
- 1 small red onion, thinly sliced
- 2 tablespoons olive oil
- 2 tablespoons balsamic vinegar
- 1/3 cup kalamatta olives
- 50g wild rocket
- Salt and pepper, to taste

1. With the Low Rack in place, preheat oven to 250°C.
2. Place eggplant on a tray and sprinkle with a generous amount of salt. Stand for 30 minutes: rinse eggplant, and pat dry with absorbent paper towel..
3. Outside the oven, arrange eggplant on the High Rack. Place tomatoes, mushrooms and capsicum on the multi-purpose baking dish.
4. Using the Oven Tongs, lower the multi-purpose baking dish and High Rack into the oven.
5. Cook for about 10 minutes or until tender.
6. Meanwhile, cook pasta in a large saucepan of salted, boiling water until tender; drain. Rinse under cold water; drain.
7. Place pasta, vegetables and remaining ingredients in a bowl. Season with salt and pepper. Toss to combine.

Beef Burgers

Serves 4

- 500g beef mince
- 1/2 red onion, finely chopped
- 2 tablespoons chopped parsley
- 1/2 cup fresh breadcrumbs
- 1 egg
- 1 tablespoon tomato sauce
- Salt and pepper, to taste
- 4 burger buns, halved
- Lettuce, tomato, cheese and sauce, to serve

1. Preheat oven to 250°C
2. Place all ingredients in a large bowl. Using your hands, mix to combine. Divide mixture into 4 equal portions; shape into patties.
3. Lightly grease the Low Rack. Outside the oven, arrange the patties on the Low Rack. Using the Oven Tongs, lower the rack into the oven. Cook for 10 minutes or until cooked through. Remove from oven; cover to keep warm.
4. Outside the oven, arrange the burger buns on the Low and High Racks. Using the Oven Tongs, lower the racks into the oven. Cook for 3 minutes or until toasted.
5. Serve burger buns topped with patties, lettuce, tomato, cheese and sauce.

Mains continued

Crispy Skinned Salmon

Serves 2

- 2 salmon fillets with skin
- 1 teaspoon brown sugar
- 1 long red chilli, finely chopped
- 1 tablespoon shredded ginger
- 1 tablespoon soy sauce
- 1 green spring onion

Steamed rice, to serve

1. Preheat oven to 250°C.
2. Outside the oven, place the salmon fillets on the High Rack. Sprinkle with brown sugar, chilli and ginger.
3. Using the Oven Tongs, lower the rack into the oven.
4. Cook for about 8-10 minutes or until cooked as desired. Serve on rice, topped with onion and soy sauce.

Lamb Roast with Potatoes

Serves 4-6

- 1.4kg leg of lamb
- 3 cloves garlic, each cut into 12 slices
- 2 rosemary sprigs, each cut into 6 lengths
- 1 tablespoon olive oil
- Salt and pepper, to taste
- 750g potatoes, chopped

1. With the Extension ring and High Rack in place, preheat the oven to 250°C.
2. Using a small sharp knife, pierce lamb all over. Press garlic slices and rosemary sprigs into each cut. Rub oil over lamb and season with salt and pepper.
3. Place the lamb into the oven. Reduce temperature to 200°C. Cook for 45 minutes.
4. Meanwhile, outside the oven, arrange potatoes on the Low Rack. Spray with cooking oil spray.
5. Use the Oven Tongs to remove the High Rack (with the lamb) from the oven. Using the Oven Tongs place the Low Rack (with potatoes) into the oven and return the High Rack (with the lamb) to the oven.
6. Increase temperature to 250°C. Cook for a further 30 minutes. Remove the lamb from the oven. Place the lamb on a plate and allow to rest for 15 minutes while the potatoes finish cooking.

Mains continued

Pork with Roast Pumpkin

Serves 6-8

- 1.1kg easy carve roast pork
- 1 tablespoon olive oil
- salt and pepper, to taste
- 750g butternut pumpkin
- Garden salad and apple sauce, to serve

1. Preheat oven to 250°C.
2. Rub oil over pork; season with salt and pepper. Outside the oven, place pork on the High Rack. Using the Oven Tongs, lower the rack into the oven. Reduce temperature to 200°C. Cook for 30 minutes.
3. Meanwhile, outside the oven, arrange pumpkin on the Low Rack. Spray with cooking oil spray
4. Use the Oven Tongs to remove the High Rack (with the pork) from the oven. Using the Oven Tongs place the Low Rack (with pumpkin) into the oven and return the High Rack (with the pork) to the oven.
5. Increase temperature to 250°C. Cook for a further 30 minutes. Remove the pork from the oven. Place the pork on a plate and allow to rest for 10 minutes while the pumpkin finishes cooking.
6. Serve pork with apple sauce, pumpkin and salad.

Basic White Bread

Makes 1 loaf

- 3 teaspoons dried yeast
- 2 teaspoons white sugar
- ½ cup (125mls) warm water
- 2 ½ cups (375g) plain flour
- 1 teaspoon salt
- 30g butter, melted
- ½ cup (125ml) warm milk

1. Place the yeast, sugar and water in a small bowl; whisk to combine. Cover and stand in a warm place for about 10 minutes or until frothy.
2. Place the flour, salt, butter, milk and yeast mixture in a large bowl; stir to combine. Turn onto a lightly floured surface and knead for about 10 minutes or until elastic. Place in a large oiled bowl, turning to coat. Cover and stand in a warm place for 1 hour or until doubles in size.
3. Lightly grease a 24cm x 14cm loaf pan.
4. Knead dough on a floured surface until smooth. Roll dough on a floured surface into a 20cm x 30cm rectangle. Roll dough from the short side into a log. Place in prepared pan and cut 3 diagonal slashes across the top. Cover and stand in a warm place for 20 minutes or until risen.
5. Meanwhile, with the Extension ring and Low Rack in place, preheat oven to 250°C.
6. Using the Oven Tongs, lower the pan into the oven. Reduce temperature to 200°C. Cook for about 40 minutes or until golden and cooked through.

Tip: Dough should not stick to the bench or your fingers when kneading, so have a little extra flour on hand to sprinkle the bench lightly if necessary.

Mains continued

Seeded Wholemeal Loaf

Makes 1 loaf

3 teaspoons dried yeast

2 teaspoons white sugar

½ cup (125mls) warm water

2 cups (300g) plain flour

⅓ cup (50g) whole meal plain flour

1 teaspoon salt

1 tablespoon olive oil

½ cup (125ml) warm milk

½ cup mixed seeds (such as pepitas, sunflower seeds, poppy seeds and sesame seeds)

2 teaspoons mixed seeds, extra

1. Place the yeast, sugar and water in a small bowl; whisk to combine. Cover and stand in a warm place for about 10 minutes or until frothy.
2. Place the flours, salt, oil, milk and yeast mixture in a large bowl; stir to combine. Turn onto a lightly floured surface and knead into a ball.
3. Make an indent in the centre and add the mixed seeds. Work the seeds into the dough, kneading for about 10 minutes or until elastic. Place in a large oiled bowl, turning to coat. Cover and stand in a warm place for 1 hour or until doubles in size.
4. Lightly grease a 24cm x 14cm loaf pan.
5. Knead dough on a floured surface until smooth. Roll dough into a 20cm x 30cm rectangle. Roll dough from the short side into a log. Place in prepared pan and cut 3 diagonal slashes across the top. Cover and stand in a warm place for 20 minutes or until risen. Lightly brush with water and sprinkle with extra seeds.
6. Meanwhile, with the Extension ring and Low Rack in place, preheat oven to 250°C.
7. Using the Oven Tongs, lower the pan into the oven. Reduce temperature to 200°C. Cook for about 40 minutes or until golden and cooked through.

Stuffed Baked Potatoes

Serves 4

4 x 200g washed potatoes

20g butter

1 tablespoon plain flour

¾ cup (180mls) milk

½ cup grated tasty cheese

125g can corn kernels, drained

2 green shallots, thinly sliced

1. With the Extension ring and High Rack in place, preheat oven to 250°C.
2. Using a fork, pierce each potato several times and wrap individually in a thin layer of foil.
3. Place the potatoes in the oven on the High Rack. Cook for about 1 hour and 15 minutes or until tender. Remove High Rack and potatoes from oven; carefully unwrap potatoes to cool slightly.
4. When cool enough to handle, trim the top of each potato; discard tops. Use a small teaspoon to scoop out the centre of the potato. Place the potato scoops in a bowl and mash with a fork.
5. Melt butter in a small saucepan over low heat. Add flour and stir to combine. Whisk in milk and simmer, whisking for about 1 minute. Remove from heat. Add cheese, corn, green shallots and mashed potato. Season with salt and pepper. Spoon mixture into potatoes.
6. Outside the oven, arrange stuffed potatoes on the High Rack. Using the Oven Tongs lower the rack into the oven.
7. Cook for about 10 minutes or until heated through.

Mains continued

Stuffed Capsicum

Serves 4

- 1 tablespoon olive oil
- 1 small onion, finely chopped
- 2 bacon rashers, finely chopped
- 1 clove garlic, crushed
- 1 ½ cups cooked rice
- ¼ cup chopped cashews
- ½ cup grated tasty cheese
- ¼ cup chopped parsley
- ½ cup fresh breadcrumbs
- 4 red capsicum

Salad, to serve

1. With the Extension ring and Low Rack in place preheat oven to 250°C.
2. Meanwhile, heat oil in a large frying pan. Add onion, bacon and garlic. Cook, stirring for about 3 minutes. Add rice, cashews, cheese and parsley.
3. Place breadcrumbs on the Multi-purpose baking dish. Using the Oven Tongs, lower the dish into the oven. Cook for about 2 minutes or until golden. Using the Oven Tongs, remove the baking dish and place the High Rack into the oven.
4. Add bread crumbs to rice mixture. Season with salt and pepper.
5. Trim the tops from the capsicum, remove the seeds and membrane; discard tops, seeds and membranes.
6. Spoon rice mixture into the capsicum. Place the stuffed capsicum into the oven. Reduce temperature to 200°C and cook for about 15 minutes or until capsicums are tender and filling is heated through. Serve with salad.

Tip: ½ cup white rice makes 1 ½ cups cooked rice.

If the capsicums don't balance upright, trim a small amount from the base (being careful not to create a hole where filling may escape).

Warm Caramelised Tomato Salad

Serves 4 (as a side dish)

- 1 clove garlic, crushed
- 1 teaspoon brown sugar
- Pinch salt
- 1 tablespoon olive oil
- 6 roma tomatoes, halved lengthways

1. Preheat oven to 250°C.
2. Place garlic, sugar, salt and oil in a large bowl. Add tomatoes and toss to coat. Outside the oven, arrange tomatoes, cut side up, on the High Rack. Add vinegar to the bowl to make dressing; set aside.
3. Using the Oven Tongs, lower the rack into the oven. Reduce heat to 200°C. Cook for 15 minutes or until soft.
4. Arrange rocket on a serving platter. Top with tomatoes, drizzle with dressing and sprinkle with basil.

Tip: Add basil and dressing immediately before serving.

Mains continued

Roast Beef with Creamy Mushroom Sauce

Serves 6-8

2 tablespoons olive oil

1.2kg beef round roast (eye roast)

Salt and pepper, to taste

100g mushrooms, sliced

1 tablespoon plain flour

$\frac{2}{3}$ cup beef consume or stock

$\frac{1}{3}$ cup cream

Chopped parsley, to serve

1. With the Extension ring and Low Rack in place, preheat oven to 250°C.
2. Rub half of the oil over beef and season with salt and pepper. Outside the oven, place beef on the High Rack. Using the Oven Tongs, lower the rack into the oven. Reduce temperature to 200°C. Cook for 20 minutes.
3. Meanwhile, place mushrooms, remaining oil and salt and pepper in a bowl; toss to coat mushrooms. Place mushrooms in the Multi-purpose baking dish.
4. Using the Oven Tongs, remove the High Rack (with beef) from the oven. Lower the Multi-purpose baking dish (with mushrooms) into the oven. Return High Rack (with beef) to the oven. Increase temperature to 250°C. Cook beef and mushrooms for a further 20 minutes.
5. Remove beef and mushrooms from the oven. Place beef on a plate and cover to keep warm. Pour any juices from the bottom of the oven into a small saucepan. Add flour and whisk until smooth. Add beef consume and whisk over a low heat, until sauce is smooth. Simmer for 1 minute. Add mushrooms and cream and continue whisking until sauce is hot.

Tip: If there are no juices left in the base of the oven, add 20g of butter to the saucepan instead.

Sweets

Chocolate Cake

Serves 12

- 125g butter, chopped
- 1 cup brown sugar
- ½ cup caster sugar
- 3 eggs
- 2 cups self-raising flour
- ⅓ cup cocoa powder
- ⅔ cup sour cream
- ½ cup water

1. With the Extension ring and High Rack in place, preheat oven to 250°C. Lightly grease (and line if possible) a 20cm ring pan.
2. Place all ingredients in a large bowl. Beat with an electric mixer on low speed until combined. Increase speed to medium, beat for about 3 minutes or until smooth and pale in colour. Pour into prepared pan.
3. Using the Oven Tongs, lower the cake pan into the oven. Reduce temperature to 180°C.
4. Bake for about 45 minutes or until cooked when tested. Stand in pan for 10 minutes before turning onto a wire rack to cool. Drizzle with chocolate ganache.

Chocolate Ganache: Place 100g chopped dark chocolate and 125ml thickened cream in a small bowl. Microwave on medium-high (70% heat) for about 1 minute, or until melted. Mix well and allow to stand at room temperature to thicken while cake cools.

Carrot Cake

Serves 12

- 1 cup canola or vegetable oil
- 1 ⅓ cups brown sugar
- 3 eggs
- 3 cups coarsely grated carrot
- 135g packet walnuts, chopped
- 2 ½ cups self-raising flour
- ½ tsp bicarbonate soda
- 1 teaspoon mixed spice

1. With the Extension ring and High Rack in place, preheat oven to 250°C. Lightly grease (and line if possible) a 20cm ring pan.
2. Place oil, sugar and eggs in a bowl. Beat with an electric mixer until creamy; stir in carrot and walnuts. Add flour, bicarbonate soda and spice; mix to combine.
3. Pour into prepared pan. Using the Oven Tongs, lower the cake pan into oven. Reduce temperature to 190°C.
4. Bake for about 1 hour 30 minutes or until cooked when tested. Stand in pan for 10 minutes before turning onto a wire rack to cool. Spread with cream cheese frosting to serve.

Cream cheese frosting: Place 250g softened cream cheese, 1 cup icing sugar mixture and 2 teaspoons lemon juice in a bowl. Beat with an electric mixer until smooth.

Sweets continued

Orange and Poppy Syrup Cake

Serves 12

1/3 cup poppy seeds

1/4 cup milk

185g butter, softened

1 1/2 cups caster sugar

1 tablespoon finely grated orange rind

3 eggs

2 cups self-raising flour

1/2 cup almond meal

1 cup orange juice

1. With the Extension ring and High Rack in place, preheat oven to 250°C. Lightly grease (and line if possible) a 20cm ring pan.
2. Combine seeds and milk in a small bowl; stand for 20 minutes
3. Meanwhile, beat butter, 1 cup of the sugar and rind in a small bowl with an electric mixer until smooth; beat in eggs one at a time until just combined between additions.
4. Transfer to a large bowl, stir in flour, almond meal, poppy seed mixture and 1/2 cup of the orange juice.
5. Spoon mixture into prepared pan. Using the Oven Tongs, place cake pan into oven. Reduce temperature to 180°C.
6. Bake for about 1 hour or until cooked when tested. Stand in pan for 5 minutes before turning onto a plate.
7. To make syrup, combine remaining orange juice and sugar in a small saucepan, stir over low heat until sugar dissolves. Bring to a boil; simmer without stirring for 2 minutes. Pour hot syrup over warm cake.

Banana Bread

Serves 8-10

2 cups self-raising flour

2/3 cup brown sugar

1 teaspoon ground cinnamon

1/2 cup milk

2 eggs

50g butter, melted

1 1/2 cups mashed over ripe banana

1. With the Extension ring and High Rack in place, preheat oven to 250°C. Grease and line a 24cm x 14cm loaf pan.
2. Place flour, sugar and cinnamon in a large bowl; stir to combine. Whisk milk, eggs, butter and banana in a large jug. Pour milk mixture into flour mixture and stir until just combined.
3. Spoon mixture into prepared pan. Using the Oven Tongs, place loaf pan into oven. Reduce temperature to 190°C. Bake for about 1 hour 10 minutes or until cooked when tested. Stand in pan for 5 minutes then turn onto a wire rack to cool.

Sweets continued

Cookies

Makes (approximately) 24

125g butter, softened

½ cup brown sugar, lightly packed

½ cup caster sugar

½ teaspoon vanilla essence

1 egg

1¾ cups self-raising flour

¼ teaspoon salt

1 cup chocolate chips

- 1 With the Extension ring and High Rack in place, preheat oven to 250°C. Lightly grease the Multi-purpose baking dish.
- 2 Using an electric mixer, beat butter, sugars and vanilla in a bowl. Add eggs one at a time, mixing well between additions.
- 3 Add flour, salt and choc chips; mix until combined. Roll tablespoons of mixture into balls; Flatten slightly
- 4 Place 6 cookies in prepared dish. Using the Oven Tongs, lower the dish into the oven.
- 5 Reduce temperature to 190°C. Cook for about 10-12 minutes or until golden. Repeat with remaining cookie dough.

Almond Shortbread

Makes 20 (approximately)

125g butter, softened

¼ cup caster sugar

1 teaspoon vanilla extract

1 cup plain flour

¼ cup rice flour

¼ cup almond meal

2 teaspoons sugar, extra

1. With the Extension ring and High Rack in place, preheat the oven to 250°C. Lightly grease the Multi-purpose baking dish with cooking oil spray.
2. Beat butter, sugar and vanilla in a small bowl with an electric mixer until pale and fluffy.
3. Transfer to a large bowl; stir in flours and almond meal in two batches. Press ingredients together and knead on a lightly floured surface until just smooth.
4. Roll dough between baking paper to 5mm thick. Using a 3.5cm round cutter, cut rounds from dough; place in prepared dish. Sprinkle shortbread rounds with extra sugar.
5. Using the Oven Tongs, lower the Multi-purpose baking dish into the oven. Reduce temperature to 180°C.
6. Bake for about 25 minutes or until lightly golden. Transfer to a wire rack to cool. Repeat with remaining shortbread.

Sweets continued

Lemon Coconut Friands

Makes 6

3 egg whites

100g butter, melted

½ cup almond meal

2 teaspoons finely grated lemon rind

2 teaspoons lemon juice

2 tablespoons shredded coconut

¾ cup icing sugar mixture

¼ cup plain flour

1. With the Extension ring and High Rack in place, preheat the oven to 250°C. Lightly grease a 6-hole muffin pan with cooking oil spray.
2. Place egg whites in a medium bowl; whisk lightly to loosen. Add remaining ingredients and stir until just combined.
3. Divide mixture among muffin holes. Using the Oven Tongs, lower the muffin pan into the oven. Reduce temperature to 190°C.
4. Bake for 20 minutes or until just cooked. Turn onto a wire rack to cool.
5. Serve dusted with icing sugar.

Tip: For mixed berry friands, remove the lemon rind and lemon juice, and a few mixed berries to the tops once they are in the pan.

Blueberry, White Chocolate and Macadamia Muffins

Makes 6

50g white chocolate, finely chopped

¼ cup macadamia nuts, roughly chopped

¾ cup self-raising flour

⅓ cup caster sugar

1 egg, lightly whisked

60g butter, melted

¼ cup milk

¼ cup frozen blueberries

Icing sugar, for dusting

1. With the Extension ring and High Rack in place, preheat the oven to 250°C. Line a 6-hole muffin pan with patty cases.
2. Place all ingredients except blueberries into a medium bowl. Stir with a wooden spoon until just combined; fold through blueberries.
3. Divide mixture among patty cases. Using the Oven Tongs, lower the muffin pan into the oven. Reduce temperature to 190°C.
4. Bake for 25 minutes or until just cooked. Stand for 5 minutes before turning onto a wire rack to cool.
5. Serve dusted with icing sugar.

Tip: Blueberries are best folded through while still frozen as this helps them to not break apart easily and “bleed” colour into your mixture.

Sweets continued

Pear Danishes

Serves 4

1 sheets ready-rolled puff pastry, thawed

2 tablespoons brown sugar

1 pear

Cooking oil spray

Cream or ice cream, to serve

1. With the Extension ring and High Rack in place, preheat oven to 250°C. Lightly grease the Multi-purpose baking dish.
2. Spray the puff pastry with cooking oil spray; cut into 4 squares. Sprinkle each square with 1 teaspoon of brown sugar.
3. Cut the pear into quarters lengthways and remove any seeds. Cut each quarter into thin slices. Fan one quarter of the pear, diagonally, onto each pastry square. Take 2 corners (opposites) of the pastry and bring to the centre above the pear; pinch to join. Spray with cooking oil spray and sprinkle remaining brown sugar over pastry.
4. Place 2 danishes in prepared dish. Using the Oven Tongs, lower the dish into the oven. Cook for about 7 minutes or until crisp and golden. Repeat with remaining 2 danishes.
5. Serve warm, with cream or ice cream.

Tip: Don't leave the pastry at room temperature for too long or it will be very soft and too hard to handle.

Notes

Notes

12 Month Replacement Guarantee

In the unlikely event that this appliance develops any malfunction within 12 months of purchase (3 months commercial use) due to faulty materials or manufacture, we will replace it for you free of charge.

Should you experience any difficulties with your appliance, please phone our customer service line for advice on 1300 881 861 in Australia, or 0800 786 232 in New Zealand. Alternatively, you can send a written claim to Sunbeam at the address listed below. On receipt of your claim, Sunbeam will seek to resolve your difficulties or, if the appliance is defective, advise you on how to obtain a replacement or refund.

Your Sunbeam 12 Month Replacement Guarantee naturally does not cover misuse or negligent handling and normal wear and tear.

Similarly your 12 Month Replacement Guarantee does not cover freight or any other costs incurred in making a claim. Please retain your receipt as proof of purchase.

The benefits given to you by this guarantee are in addition to your other rights and remedies under any laws which relate to the appliance.

Our goods come with guarantees that cannot be excluded under the Australian Consumer Law and under the New Zealand Consumer Guarantees Act.

In Australia you are entitled to a replacement or refund for a major failure and for compensation for any other reasonably foreseeable loss or damage. You are also entitled to have the goods repaired or replaced if the goods fail to be of acceptable quality and the failure does not amount to a major failure.

Should your appliance require repair or service after the guarantee period, contact your nearest Sunbeam service centre.

For a complete list of Sunbeam's authorised service centres visit our website or call:

Australia

www.sunbeam.com.au

1300 881 861

Units 5 & 6, 13 Lord Street
Botany NSW 2019 Australia

New Zealand

www.sunbeam.co.nz

0800 786 232

26 Vestey Drive, Mt Wellington
Auckland, New Zealand

Need help with your appliance?

Contact our customer service team or visit our website for information and tips on getting the most from your appliance.

In Australia

Visit www.sunbeam.com.au

Or call 1300 881 861

In New Zealand

Visit www.sunbeam.co.nz

Or call 0800 786 232

 is a registered trademark.

'NutriOven' is a trademark of Sunbeam Corporation.

Made in China.

Due to minor changes in design or otherwise, the product may differ from the one shown in this leaflet.

© Copyright. Sunbeam Corporation Limited 2011.

ABN 45 000 006 771

Units 5 & 6, 13 Lord Street
Botany NSW 2019 Australia

Unit 3, Building D
26 Vestey Drive
Mt Wellington Auckland
New Zealand

Sunbeam Corporation is a division of GUD Holdings Ltd.