

Reversible Panel Frame Router Bits

Reversible Ogee Frame Bit
Reversible Panel Frame Bit
Reversible Classic Frame Bit

16J67.01/.51
16J67.02/.52
16J67.03/.53

Suitable for stock $\frac{5}{8}$ " to $\frac{15}{16}$ " thick. $\frac{3}{4}$ " to $\frac{7}{8}$ " is optimal.

 For better safety, use this bit in a router table only – **not free hand.**

Creating a Sizing Block

A sizing block is a short length of wood with a cut along one edge made by the profiling cutter of the bit. (See **Figure 1.**) It is required for setting the cutter spacing when the bit is assembled for the sticking cut. The block should be made from a dense hardwood (maple, birch, etc.) and should be about $\frac{1}{2}$ " thick. As the sizing block will be required each time the bit is used, it should be labelled and kept with the bit.

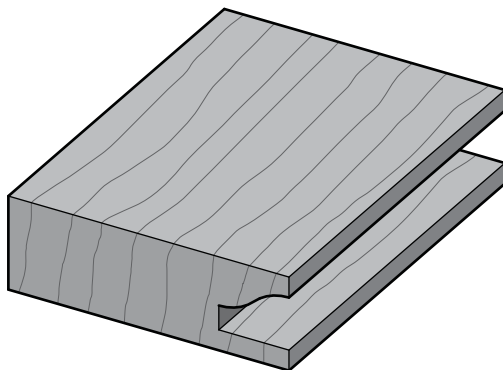

Figure 1: Sizing block.

To make the sizing block, install the bit in a table-mounted router. The height of the bit should be set to leave material above and below the profiling cutter (see **Figure 2**). It doesn't matter which way the bit is assembled for this cut. The bearing should be set flush with the face of your fence. Run the block through.

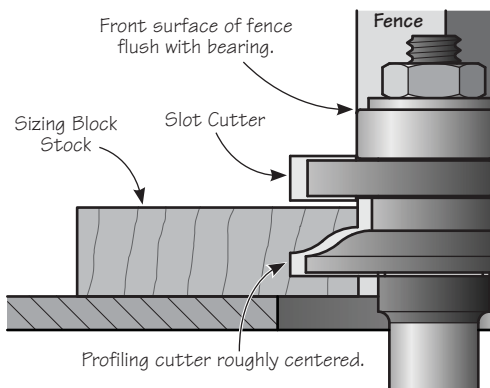

Figure 2: Set-up for sizing block.

Cutting the Frame Members

1. Cut all stock for the frame members longer than needed. Cut extra pieces to be used for router set-up. All pieces must be flat and of consistent thickness. The final length for the rails and mullions is $\frac{3}{4}$ " longer than the visible length.

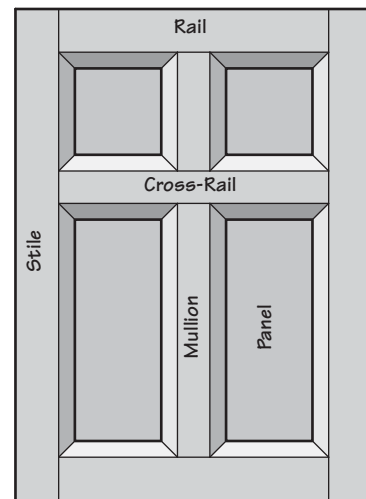

Figure 3: Door parts.

2. Assemble the router bit for the sticking cut, as shown in **Figure 4**. Install the bit in a table-mounted router and run a length of scrap through to test the cutter spacing (dimension D shown in **Figure 4**).

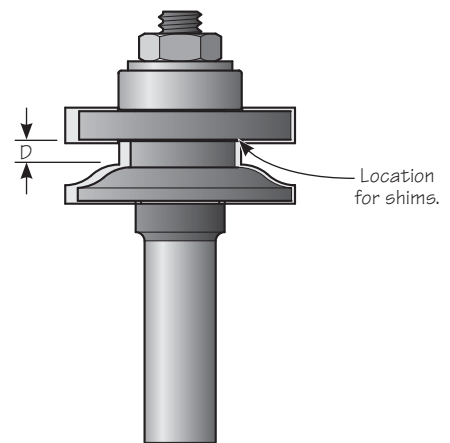
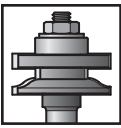

Figure 4: Bit assembled for sticking cut.



- Use the sizing block to check the spacing of the cutters. (See **Figure 5**.) If the test piece is too tight or does not fit into the sizing block, shims between the cutters need to be removed. If the fit is too loose, more shims must be added. Repeat the test cut until a satisfactory fit is achieved. Make a note (on the sizing block) of the number (or thickness) of shims used for future reference.

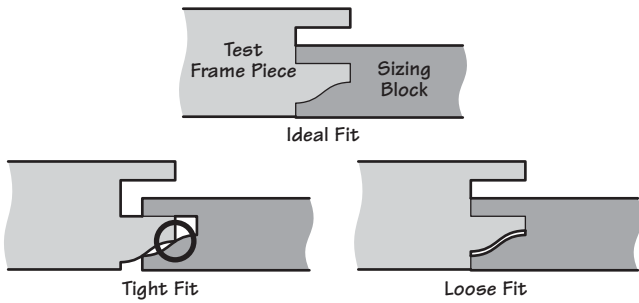

Figure 5: Testing the cutter spacing.

- Adjust the height of the bit so that a small shoulder will be cut on the inner face of the frame pieces (see **Figure 6**). Set the router table fence flush with the pilot bearing. Rout the inner edge of all the frame pieces (stiles and rails) and both long edges of the mullions and cross-rails.

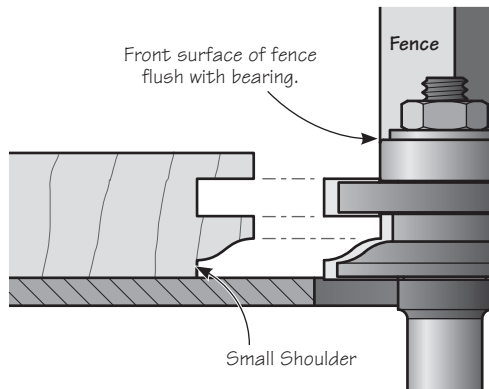

Figure 6: Set-up for sticking cut.

- Cut the rail and mullion pieces to the required length.
Note: The length for the rails and mullions is 3/4" longer than the visible length.
- Reassemble the router bit for the coping cut (i.e., cutting the end grain of the rails and mullions), as shown in **Figure 7**. Set the bit height to approximately match a previously cut frame piece. Run a length of scrap through to test the cutter spacing.

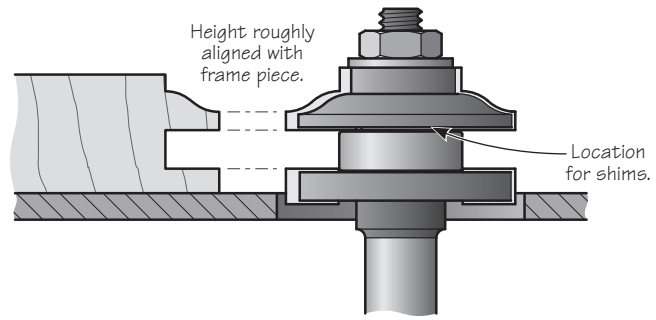

Figure 7: Bit assembled for coping cut.

- Test the fit of the tongue with a frame piece (see **Figure 8**). If the fit is too tight, remove shims. If the fit is too loose, more shims are required. Do not make the tongue fit too tight or you risk splitting the back of the stiles.

Note: The bit does not need to be at the correct height in order to test the fit.

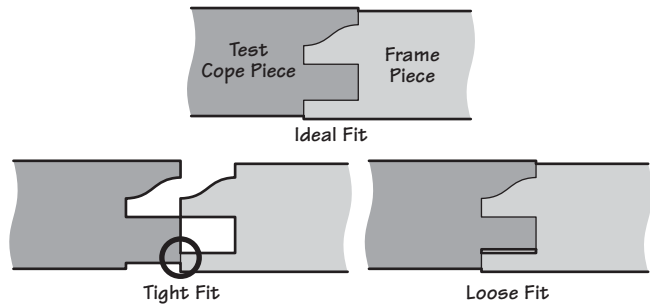

Figure 8: Testing the fit of the tongue.

- Once the fit has been perfected, adjust the bit height using one of the previously cut rails or stiles as a guide (see **Figure 9**).

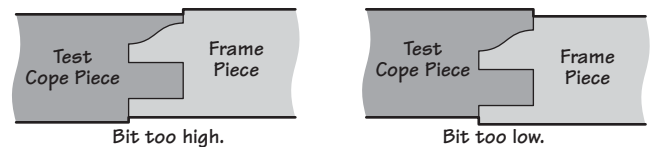

Figure 9: Checking the bit height.

- Use a right-angle fixture to guide the ends of the rails and mullions through the router (see **Figure 10**). Use a scrap piece of stock with a coping cut along its length to support the rails and mullions to prevent tear-out.

*Note: The coping cut on the scrap stock used to prevent tear-out must be cut **after** the bit height has been perfected.*

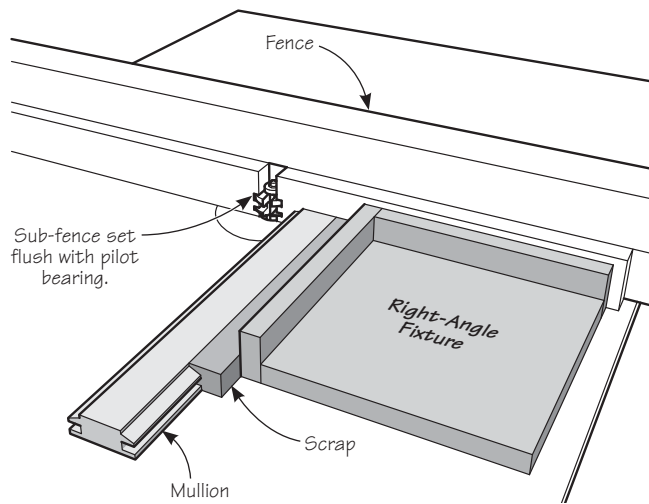
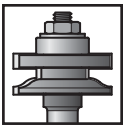
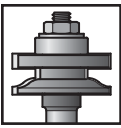

Figure 10: Using a right-angle fixture.

10. Dry-assemble the frame and panel, and check for proper panel fit. The panel width should be $\frac{1}{8}$ " less than the rail length to allow for seasonal movement. Glue up the frame, but **do not** glue the panel to the frame.



Reversible Panel Frame Router Bits
Instructions



1090 Morrison Drive 814 Proctor Avenue
Ottawa, Ontario Ogdensburg, New York
K2H 1C2 Canada 13669-2205 USA
1-800-267-8761 1-800-267-8735
customerservice@leevalley.com