



PORTA-NAILS, INC. • PO BOX 1257 • WILMINGTON, NC 28402 • 910-762-6334 • 800-634-9281 • FAX 910-763-8650
HOME PAGE: www.porta-nails.com E-MAIL: info@porta-nails.com

OWNER'S MANUAL



PORTAMATIC® Pneumatic Nailer

**For Tongue and Groove Solid Wood & Hardwood Laminate
Flooring, Roof Decking and Wood Sub Flooring**



CAUTION - Read important safety instructions AND operation instructions BEFORE operating your PORTAMATIC® Pneumatic Nailer.

Your new **PORTAMATIC® Pneumatic Nailer** is a quality-built machine, capable of dependable performance throughout its lifetime. To take full advantage of these capabilities you should thoroughly understand the proper method and technique of its operation. Therefore, we suggest you read this manual before operating and that you save it for future reference.

FORM P/N 750048 (6/1/2002)

PORTAMATIC®



CAT. NO. 421 **SPECIFICATIONS**

ETL Listed:	Control Number 9801577
US Patent Numbers:	6,095,392 & D419,048
Fastener Type:	Use only Porta-Nails*
Operating Pressure:	90 P.S.I. (See Operating Instructions Pg. 7)
Firing Mode:	Hammer Actuated
Jam Clearance:	Hinged Lever Type, Quick Release Gate (See Clearing a Jam Pg. 9)
Dimensions:	19" High x 20" Long x 3" Wide
Weight:	Approximately 13 LBS.

***Porta-Nails** Must Be Purchased Separately

PNI's LIMITED TWO YEAR WARRANTY

PNI is proud of the products that it manufactures and warrants them to be free from defects in materials and workmanship for 2 years. In the unlikely event that a problem occurs, return the product to our plant freight prepaid and allowed, so that a determination of the fault can be made. If the fault is determined to be defective materials or workmanship, a no-charge replacement or repair will be made, at our discretion. The product will be returned to you freight prepaid and allowed. This warranty does not cover accidents, abuse or misuse and in no case will PNI be liable for incidental or consequential damages. No other warranty written or verbal is authorized. Returns for warranty service should be sent to:

Porta-Nails, Inc.
4235 US Hwy. 421 N.
Currie, NC 28435

Safety Instructions

1. **KNOW YOUR POWER TOOL**
Read the owner's manual carefully. Learn its applications and limitations as well as the potential hazards specific to this tool.
2. **THE OPERATOR AND ALL OTHER PERSONNEL MUST WEAR PROPER EYE AND EAR PROTECTION IN THE WORK AREA.**
Wear safety goggles at all times. (Must comply with ANSI Z87.1). Everyday eyeglasses have impact resistant lenses only. They are NOT safety glasses. Also, wear ear protectors (plugs or muffs) during extended periods of operation
3. **KEEP WORK AREA CLEAN**
Cluttered areas and benches invite accidents. Floor must not be slippery due to sawdust.
4. **KEEP CHILDREN AWAY**
All visitors should be kept a safe distance from work area.
5. **WEAR PROPER APPAREL**
Do not wear loose clothing, gloves, neckties or jewelry (rings, wristwatches) that could get caught in moving parts. Wear non-slip footwear. Wear protective hair covering to contain long hair. Roll long sleeves above the elbow.
6. **SECURE WORK**
Be sure the tongue and groove of the flooring strips are properly interlocked and secured in place before nailing.
7. **STAY ALERT**
Watch what you are doing. Use common sense. Do not operate tool when you are tired or while under the influence of medication, alcohol or drugs.
8. **ALWAYS INSPECT TOOL BEFORE OPERATING.**
Tool must be inspected prior to use to insure proper use of power supply. Tool must be inspected to insure proper working order. An improperly functioning tool must not be used
9. **KEEP HANDS, FEET AND OTHER BODY PARTS AWAY FROM NAIL EJECTION AREA.**
Serious injury could occur if body parts are not kept away from nail ejection area.
10. **ALWAYS ASSUME THE TOOL CONTAINS FASTENERS.**
Do not activate the tool unless the tool is placed firmly against the work piece.
11. **NO HORSEPLAY.**
Do not point the tool toward yourself or anyone whether it contains fasteners or not.
12. **NEVER TRANSPORT TOOL WHILE DEPRESSING THE TRIGGER.**
13. **DISCONNECT TOOL FROM AIR SUPPLY WHEN:**
Moving the tool to a new location, performing any maintenance or repair, clearing a jam or tool is unattended.
14. **NEVER SERVICE WHILE ATTACHED TO AIR SUPPLY.**
Always disconnect the tool from the power source when servicing, or replacing parts.
15. **DO NOT USE TOOL IF OPERATING CONTROLS ARE INOPERABLE.**
Do not remove, tamper with, or otherwise cause the tool operating controls or safety controls to become inoperable.
16. **DO NOT OPERATE TOOL IF SAFETY FEATURES NOT WORKING PROPERLY.**
Disconnect tool from power source if safety trigger or operating controls are not working properly.
17. **USE ONLY PORTA-NAIL FASTENERS.**
Only use fasteners recommended by the manufacturer. Use of other fasteners may cause serious injury, jamming of tool or improper operation.
18. **USE ONLY PRESSURE-REGULATED POWER SOURCE.**
Use only a pressure regulated power source set at 125 psi maximum. The power source must have a safety relief valve set at 135 psi maximum.
19. **THE TOOL SHOULD NOT BE OPERATED AT THE MAXIMUM AIR PRESSURE.**
The tool air-line should be connected to the power source through an airline pressure Regulator and an airline Filter. The air line Regulator should never be set higher than 110 psi as marked on the tool. Lower pressures may be used as recommended by the manufacturer.
20. **HAZARDOUS POWER SOURCES SHALL NOT BE USED.**
Hazardous power sources including, but not limited to, Oxygen, Combustible gases, sources whose pressure can exceed 200 psi if the pressure Regulator fails, bottled gases, including air should never be used.

APPLICATIONS

Your model 421 **PORTAMATIC®** Nailer is designed for Face Nailing and Angle Nailing 9/16", 25/32", and 33/32" Hardwood Tongue and Groove Flooring. (See **Shoe Accessory Applications** section)

PORTAMATIC® ACCESSORY SHOE APPLICATIONS

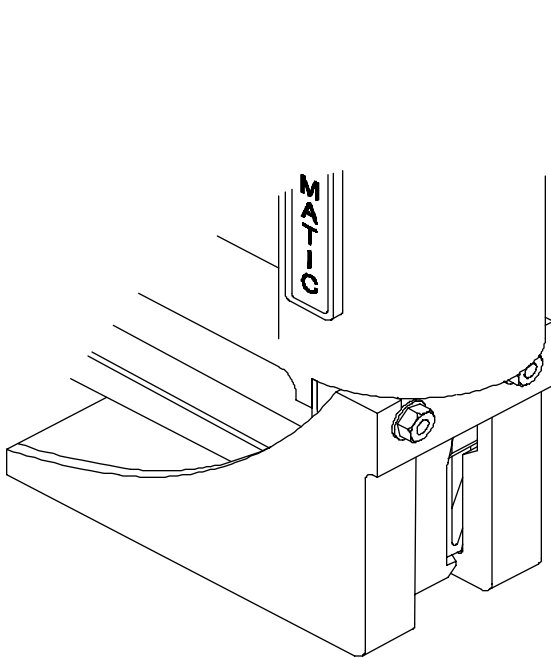

FIGURE 1

Face Nailing

Accessory Shoe Cat. No. 50113

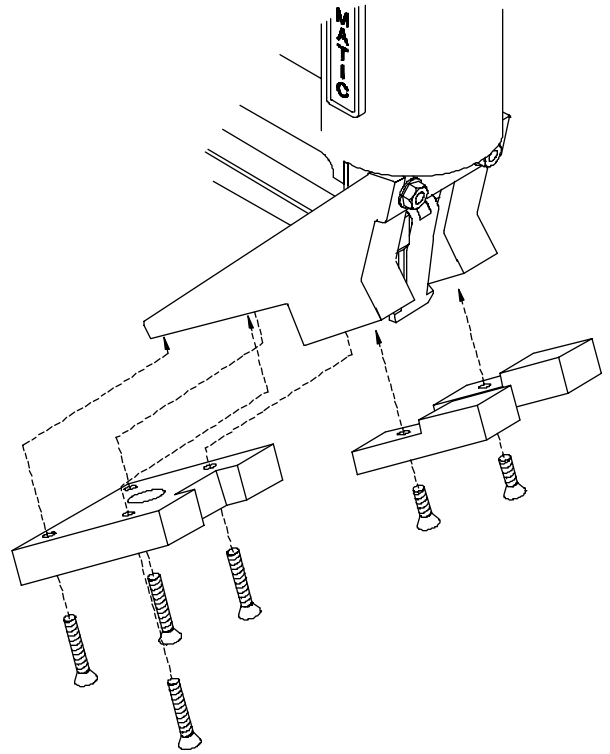

FIGURE 2

Tongue Nailing 33/32" Flooring

Shoe P/N 50125

Shoe Base and Pads

Accessory P/N 50250

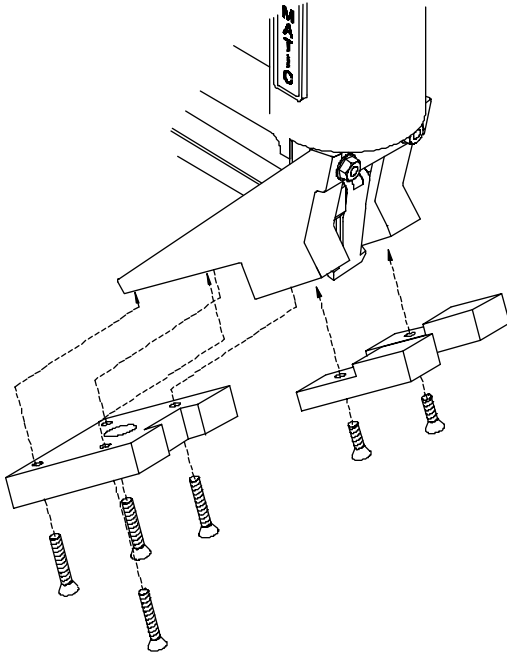

FIGURE 3
Tongue Nailing 3/4" Flooring
 Shoe P/N 50125
 Shoe Base P/N 50115
 Shoe Pad P/N 50114

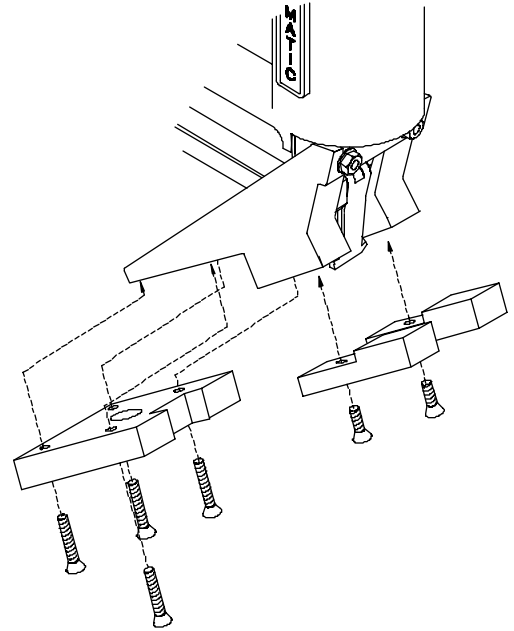

FIGURE 4
Tongue Nailing 9/16" Flooring
 Shoe P/N 50125
 Shoe Base and Pad
 Accessory P/N 50246

SHOE CHANGING

CONVERSION TO AND FROM FACE NAILING

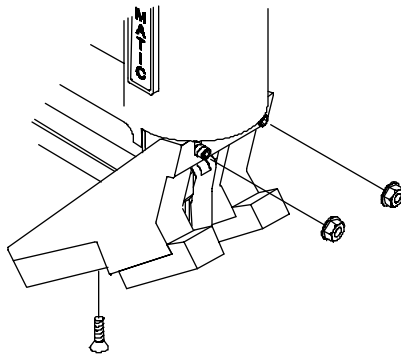

FIGURE 5
Tongue and Groove Flooring Shoe
 Cat. No. 50111

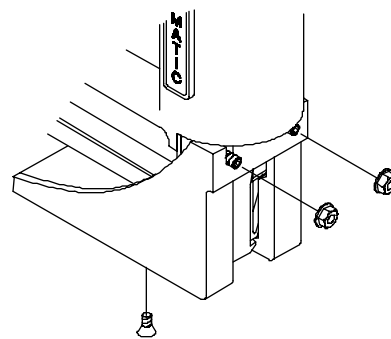

FIGURE 6
Face Nailing Shoe
 Cat. No. 50113

Loosen or remove Flange Nuts (Ref. No. 33) with Wrench and Shoe Screw (Ref. No. 50) to remove and change over from Tongue Nailing to Face Nailing Applications. Change from Face Nailing to Tongue Nailing by loosening or removing Flange Nuts (Ref. No. 33) with Wrench and Face Shoe Screw (Ref. No. 42).

Nailing Tongue And Groove Flooring

Using the PORTAMATIC® Nailer

1. Install the Face Nailing Shoe on the **PORTAMATIC®** Nailer (See **Shoe Changing** Section Pg. 5 Figure 6).
2. After squaring the Floor and allowing for expansion as recommended by the Wood Flooring Industry (NWFA, NOFMA and MFMA), place the grooved edge of the first row of Flooring towards the wall on the side of the room from which you are starting.
3. Be careful to use the Brown Cap of the Hammer to hit the Ram Head of the **PORTAMATIC®** Nailer and the Gray Cap on the Flooring. Using the Brown Cap to hit the Flooring will destroy the Cap.
4. Depress Safety Trigger, and strike Ram Head of the **PORTAMATIC®** Nailer with the Face Nailing Shoe installed.
5. After striking the Ram Head, the actuating cycle of the **PORTAMATIC®** Nailer drives one nail into the Flooring.
6. When the nail has been completely driven, the **PORTAMATIC®** Nailer will automatically reset, and is ready to be moved to the next position and drive another nail.
7. Be careful not to drive one nail on top of another. Damage to the Nailer might result or injury from sparks or a sliver of metal that might break away if this should occur.
8. If a nail is driven on top of another or a jam occurs, refer to the “Clearing a Jam” section of the manual on page 9.
9. Slide the **PORTAMATIC®** Nailer along the Flooring to the location at which you desire to drive the next nail.
10. Continue until four (4) rows of Flooring have been Face Nailed.
11. Remove the Face Nailing Shoe Accessory from the **PORTAMATIC®** Nailer and install the Tongue and Groove Nailing Shoe (See **Shoe Changing** Section Pg. 5 Figure 5).
12. Place the groove of the fifth row of Flooring over the tongue of the fourth row of Flooring and tighten using the Hammer. Depress Safety Trigger, and strike Ram Head of the **PORTAMATIC®** Nailer with the Tongue and Groove Nailing Shoe installed.
13. Slide the **PORTAMATIC®** Nailer along the tongue of the Flooring to the location at which you desire to drive the next nail.
14. Continue Step 11 until you have completely nailed all but the last five (5) rows of Flooring.
15. Remove the Tongue and Groove Nailing Shoe from the **PORTAMATIC** Nailer and install the Face Nailing Shoe (See **Shoe Changing** Section Pg. 5 Figure 6).
16. Install and nail in place the remaining five (5) rows of Flooring using the **PORTAMATIC®** Nailer with the Face Nailing Shoe installed.

Operating Instructions

Safety Requirements

1. **WEAR SAFETY GLASSES** and safety shoes for protection against foreign objects.
2. **NEVER** use a Hammer with a loose head or splintered handle.
3. **USE ONLY** nails from Porta-Nails, Inc.
4. Air supply hoses should have a minimum working pressure rating of 150 PSI or 150 percent of the maximum pressure produced in the power source, whichever is higher.
5. Check all hoses before connecting to ensure that they are free from dirt, grit, or particles that could alter the performance of the tool.
6. An airline Filter and Regulator are required.
7. The **PORTAMATIC®** pneumatic Nailer requires **Clean, Dry Air**. **DO NOT USE IN-LINE OILERS WITH THE PORTAMATIC®**. Dust, dirt and other particles in the system can cause premature wearing of the major components. Cylinder, piston, and o-rings are especially sensitive to wear caused by dirt abrasion.
8. Adjust the airline Regulator to **90-95 PSI**. Be sure that the tool is not pointed at you or others when it is connected to the air supply source.
Note: Some materials may require a higher pressure of 95-100 PSI in order to countersink the nail.
9. **NEVER** use a defective tool. Replace worn or damaged parts immediately. Be sure that the Safety Trigger and operating mechanisms operate correctly and that all screws and seals are securely tightened at all times.

Installing A Fitting

Before using the **PORTAMATIC®** Nailer, a 3/8" NPT Fitting must be installed. The **PORTAMATIC®** Nailer has an adapter installed to accept a 3/8" NPT fitting. This provides the owner the advantage of installing the preferred 3/8" NPT Fitting of choice. This allows the freedom to use any configuration of quick connect 3/8" NPT Fitting. Install the 3/8" NPT Fitting into the supplied adapter and gently tighten.

IMPORTANT: The bottom hole of the **PORTAMATIC®** that is plugged should **NEVER** be removed. If plug is removed, the **PORTAMATIC®** Nailer will not perform correctly and serious damage may occur.

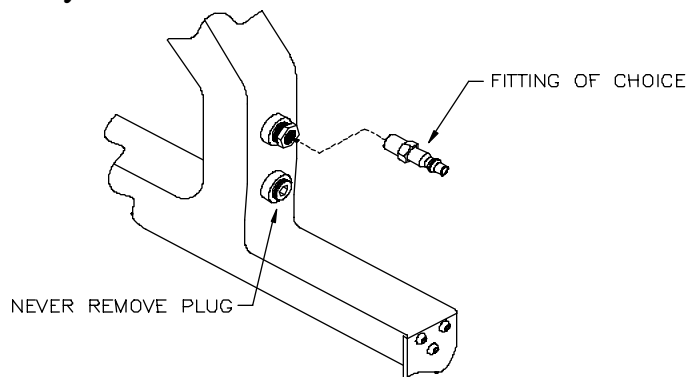

Loading the Tool

Insert nails into the nail track and pull back the Pusher Bracket (Ref. No. 19 Pg. 17) to provide pressure against the nails. **IMPORTANT! For proper operation, never use the PORTAMATIC® Nailer with less than a 2 inch stack of nails remaining in the nail track.**

Operation

1. After connection with power source is made, check to be sure that the airline Regulator pressure is **90-95 PSI**. **Note:** Some materials may require a higher pressure of 95-100 PSI in order to countersink the nail.
2. Ensure that tool is in proper working order and that there is no leaking of air. If there is an air leak, **Disconnect Immediately!** Refer to the Repair and Maintenance section of Owner's Manual.
3. After being sure tool is operable, place tool in position to be used. Always place the tool in proper position against the Flooring to be nailed before striking the Ram.
4. The **PORTAMATIC®** Nailer has a Safety that prevents accidental firing if Ram Cap is hit while connected to power source. Squeeze Safety Lever to enable the Nailer. Releasing the Safety Lever re-engages the Safety and renders the Nailer in operable.

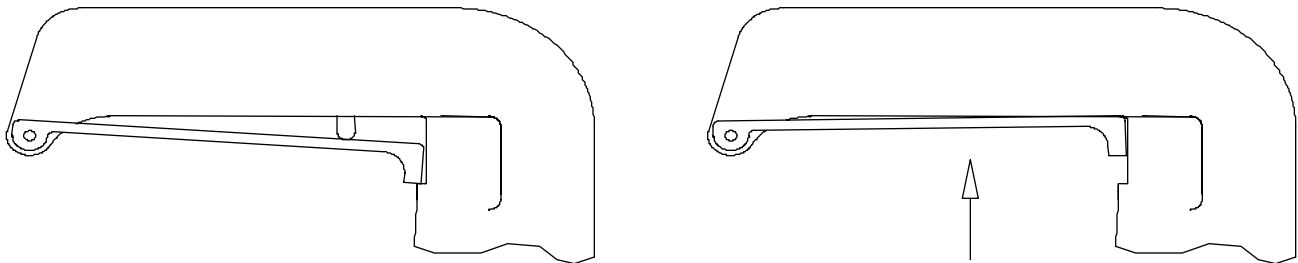

5. To operate tool, depress Safety Trigger while tool is in position of use, and strike the Ram Cap (Ref. No. 47 Pg. 17).
6. If on the first initial operation a nail does not eject into the Flooring, repeat Hammer blow. This will ensure that the Driver Blade/Piston is properly reset to allow the Driver Blade/Piston (Ref. No. 36 Pg. 17) to be in the correct position to drive the nail.
7. **DO NOT OVERPOWER THE NAILER** – A minimal stroke of the hammer will fire the Nailer. If the Flooring is warped or bowed, the Ram can be hit firmly to tighten the Flooring. Try to avoid this constant wear, as abusive blows by the hammer could damage tool.
8. **Note:** The **PORTAMATIC®** Nailer will not drive a nail if the Ram Cap is struck by Hammer and the Safety Trigger is not depressed.
9. The **PORTAMATIC®** Nailer is user-friendly and following these simple instructions, will insure a very high quality Hardwood Flooring installation.
10. If the nail is not properly seated, increase pressure incrementally until nail is seated. **DO NOT EXCEED 110 PSI!**

Clearing A Jam

1. In the event of a jam, the Gate (Ref. No. 22 Pg. 17) can be opened by pulling the gate clip upward. (See Figures 7 and 8) (The Shoe does not have to be removed to open and close the Gate.)
2. **IMMEDIATELY DISCONNECT** from power source until jam is cleared!
3. Once Gate is open, clear jam.
4. Inspect to be sure no damage has been done to the Driver Blade, Guide, Gate, Magazine or Pusher Finger. (If damage has occurred, repair immediately before connecting to the power source and continuing.)
5. Close Gate by placing the Gate Clip Wire over the two hooks of the Guide as shown and press down to seat and lock the Gate in place. Make sure the Gate is properly reseated.
6. **DO NOT OPERATE WITH GATE OPEN!**

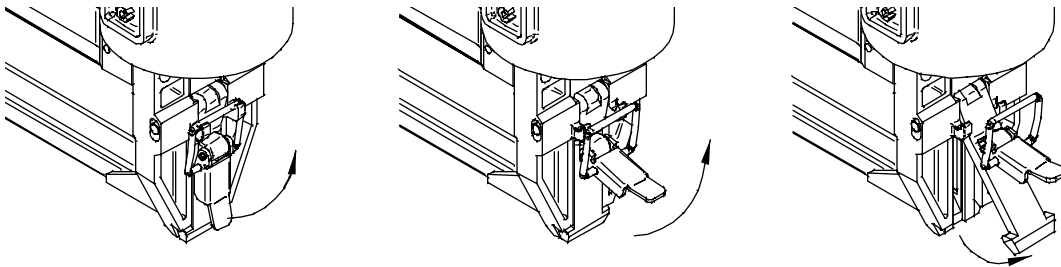

Figure 7

Pull the tab of Gate Clip to open Gate. Opening the Gate allows access to the Nail Chamber.

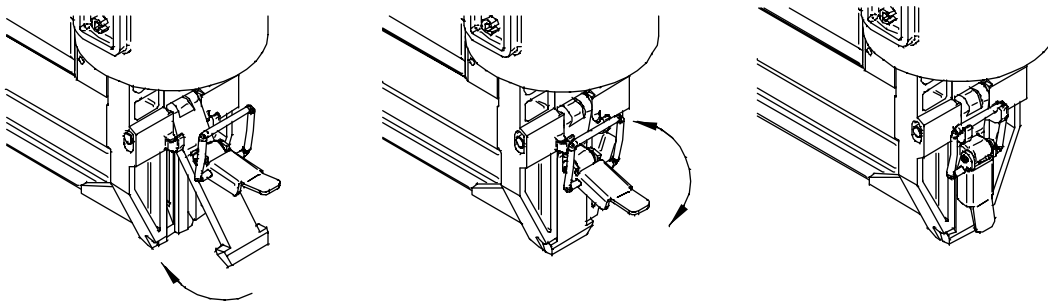

Figure 8

To Close Gate, reset the Gate tab ends under the ears of the Guide. Reset the Gate Clip Wire over the two hooks of the Guide and pivot Gate Clip down until seated.

Ensure Gate is secure before continuing operation.

Repair and Maintenance

IF AIR IS LEAKING FROM THE NAILER DISCONNECT IMMEDIATELY!

If air is leaking from the Nailer, inspect to make sure Main Housing or Extension Handle is not cracked or damaged. If Main Housing and Extension Handle are not damaged, the head gasket or an O-Ring may need to be replaced. Refer to Exploded view Page 17 for Disassembly.

1. Remove Extension Handle (Ref. No. 15 Pg. 17) from Main Body and Main Valve Housing (Ref. No. 46).
2. Remove Main Valve Housing Screws (4) and remove Main Valve Housing.
3. Check the Head Gasket (Ref. No. 6) to ensure proper positioning and/or check for a tear or pinched edge around the screw holes.

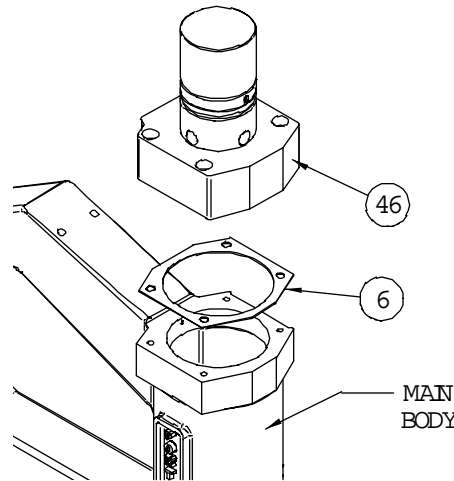

FIGURE 9

4. If Head Gasket does not look damaged, check Main Valve Upper and Lower O-Rings and Seal. Remove Ram Head Set Screw and inspect. Replace if O-Ring is broken or flattened in one or more spots. Refer to Figure 11 in the “Replacing O-Rings” section.

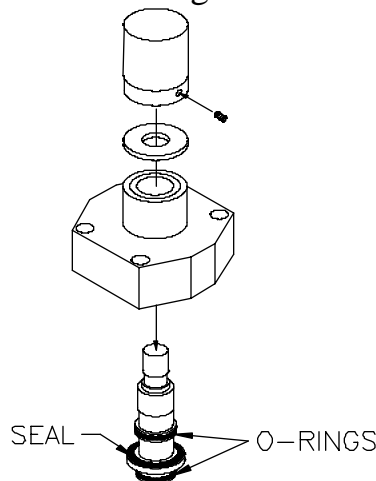

FIGURE 10

If the Seal is damaged or has separated from the Main Valve, replace Main Valve. The Seal and Main Valve have been assembled permanently at the Manufacturing Facility and can not be repaired in the field.

5. Inspect other O-Rings as described in “Replacing O-Rings” section Figures 12-16 to ensure proper positioning and distortion has not taken place. If any of the O-Rings are distorted, refer to the proper Figure and replace.
6. After inspecting and/or replacing O-Rings, assemble Nailer and connect to power supply.

Replacing O-Rings

Use Texaco Molytex® EP 2 Grease or equivalent. Do not use greases that cause O-Rings to swell. The use of these types of greases may prevent Nailer from operating properly. **NEVER USE OIL FOR LUBRICATION!**

FIGURE 11
Main Valve

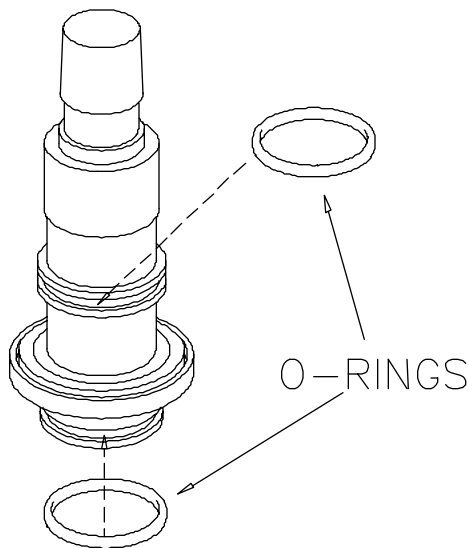

O-Ring is used both on the upper groove as well as the lower groove. The flat seal in the middle can not be replaced. Grease O-rings.

FIGURE 12
Cylinder

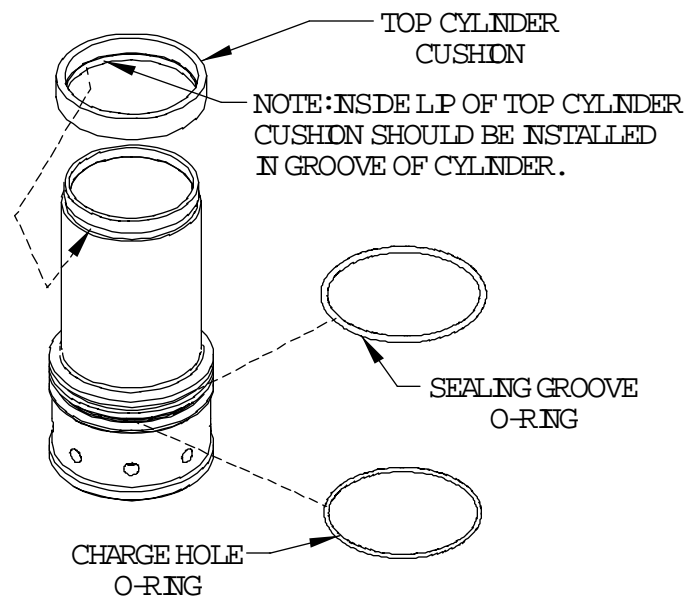

Top O-Ring is used on the sealing groove. Bottom O-Ring is used on the groove with the charging holes. Grease O-rings. Top Cylinder Cushion should be positioned as shown with the inside Lip installed in the top Groove of the Cylinder. Cushion Lip should be securely “seated” in groove.

FIGURE 13

Cylinder Discharge Valve

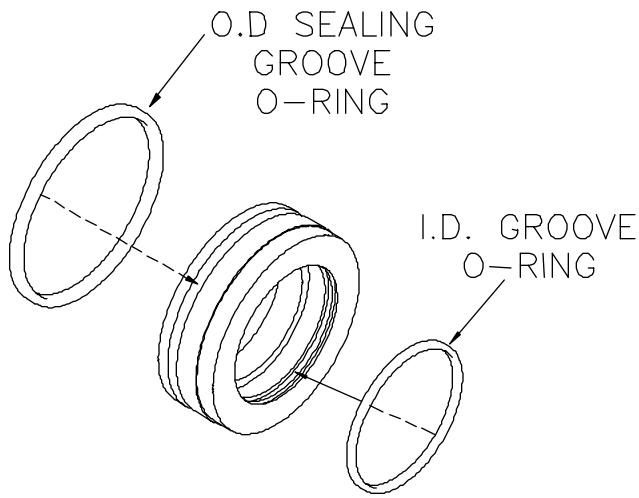

O-Ring is used on the O.D. sealing groove. O-Ring is used on the I.D. groove of the Cylinder Discharge Valve. Grease O-rings.

FIGURE 14

Valve Body

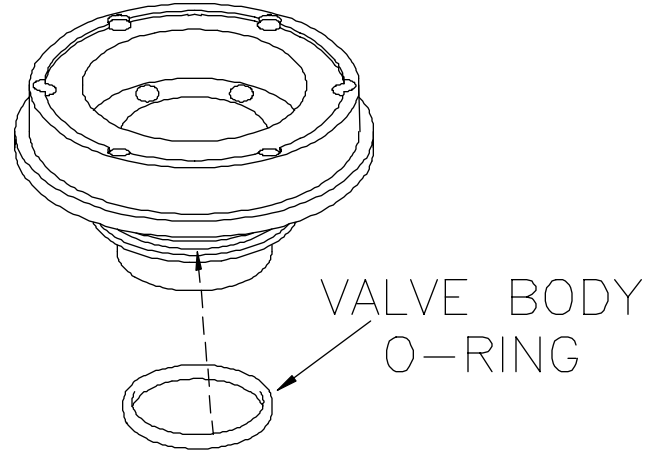

O-Ring is used on the sealing groove of the Valve Body. Grease O-ring.

FIGURE 15

Driver Blade & Piston Assembly

O-Ring is used on the sealing groove of the Piston. Grease O-ring.

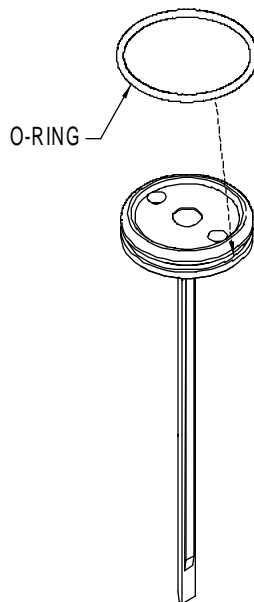

Replacing the Driver Blade/Piston Assembly

1. Remove Extension Handle from Main Body and Main Valve Housing.
2. Remove Main Valve Housing Screws (4) and remove Main Valve Housing.
3. Remove Piston Assembly from the Cylinder.
4. Check that the Driver Blade is tightly held and does not move freely.
5. Apply Molytex MP2 Grease or equivalent to the O-ring around the piston. **NEVER USE OIL FOR LUBRICATION.**
6. When assembling the Driver Blade and Piston in the Cylinder, be sure the Beveled side of the Driver Blade faces the Magazine Side of the Guide.

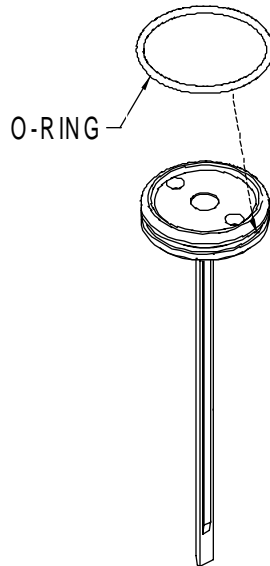

Removing and Re-Installing the Cylinder Assembly

1. After removing the Extension Handle and Main Valve Housing, remove the Head Gasket, Valve Body Assembly and the Piston Assembly.
2. Turn the Nailer over and tap lightly on a hard surface carefully insuring not to damage the Body in anyway.
3. The Cylinder should dislodge enough to enable grasping and removing.
4. To replace the Cylinder, **grease O-rings** and make sure the Piston Cushion is installed in the bottom of the Cylinder and push the Cylinder back down into the Body.
5. Push Cylinder down to reseal the external O-ring in the Body and ensure the Cylinder and Piston Cushion are seated at the bottom of the Body.

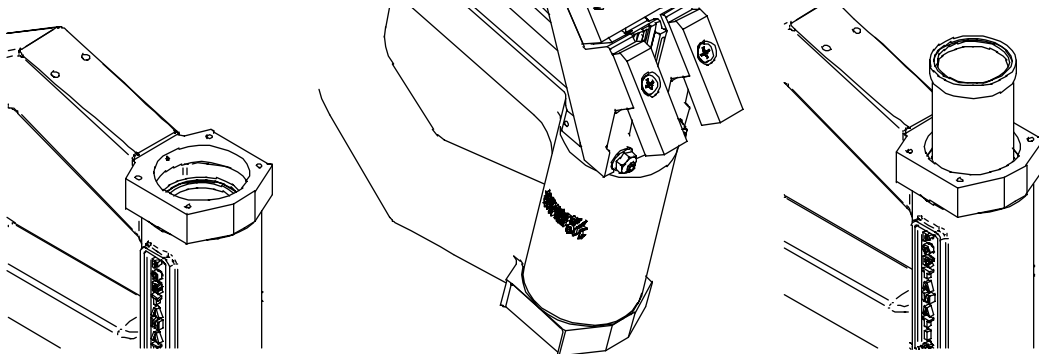

ACCESSORIES

The testing of this tool has been accomplished with the following accessories. For safest operation, it is recommended that only these accessories be used with this product.

WARNING- Since accessories other than those listed have not been tested with this product; use of such accessories could be hazardous.

<u>REF. NO.</u>	<u>PART NO.</u>	<u>DESCRIPTION</u>
Not Shown	50104	O-Ring Repair Kit
Not Shown	50172	Grease
Not Shown	50250	Shoe Base & Pads for 33/32" Flooring
Not Shown	50246	Shoe Base & Pads for 9/16" Flooring
Not Shown	50139	Hex Wrenches
Not Shown	50318	Wrench – Shoe / Body Flange Nuts
Not Shown	50039	Hammer (Brown Cap for Ram Head, Gray Cap for Floor)
Not Shown	50299	Hammer Cap (Brown)
Not Shown	50170	Safety Glasses
Not Shown	50038	Case - PORTAMATIC®
Not Shown	42623	Porta-Nails 10 packages of 1000 2" Nails

RECOMMENDED EQUIPMENT

Air Compressor - 1-1/2 HP, approximately 5CFM at 100 PSI. An airline Pressure Regulator set at 90-95 PSI should control line pressure. Air Compressor must have a Condensate Drain at bottom of Accumulator Tank. Drain every 24 hours or after every day's use. **DO NOT USE OIL LUBRICATOR WITH THE PORTAMATIC.**

★ There should be an Air-Line Filter between the Pressure Regulator and the Air Compressor. Filter on Air-Line must be drained after use every day.

Hose - 100' – 3/8" I.D.

Fitting - 3/8" NPT

USE OF THE Porta-Nail

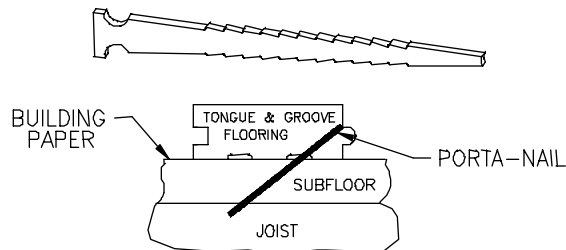

The Porta-Nail is 2" long and the PORTAMATIC® with the standard shoe drives the nail into the tongue and groove flooring at a 45-degree angle. The orientation of the nail is as depicted in wood floor joist construction.

<u>REF. NO.</u>	<u>PART NO.</u>	<u>DESCRIPTION</u>
1.	1575	Screw–Handle/Valve Housing (2 ea.)
2.	1589	Screw – Handle / Body (2 ea.)
3.	50280	Washer – Return Spring
4.	50010	Screw – Shoe / Body (2 ea.)
5.	50294	Cylinder Cushion Ring
6.	50012	Head Gasket
7.	50013	Cylinder Exhaust Valve
8.	50018	Spring - Return
9.	50019	Spring - Discharge (3 ea.)
10.	50020	Piston Cushion
11.	50023	Discharge Valve & O-Rings
12.	50025	Cylinder & O-Rings
13.	50015	Valve Body & O-Ring
14.	50431	Gate Clip & Pin
15.	50160	Extension Handle Assembly W/Safety (Includes 39,40,45)
16.	50402	Pusher Pull Screw
17.	50062	Spring - Constant Force & Screw (Ref. 18)
18.	50064	Screw – Constant Force Spring
19.	50413	Pusher Assembly (Includes 16,25,38)
20.	50067	Spring Spool (2 ea.)
21.	50102	Guide Assembly (Includes 14,25,38)
22.	50080	Access Gate
23.	50327	Restrictor Plate
24.	50085	Dowel Pin – Gate / Guide
25.	50403	Pusher Wheels & Screws (4 ea.)
26.	50158	Rail
27.	50090	Magazine Retainer Bracket
28.	50098	Magazine
29.	50101	Screws – Magazine / Bracket (2 ea.)
30.	50103	Ram Washer
31.	50114	Shoe Base Pad - 3/4 Flooring (2 ea.)
32.	50115	Shoe Base - 3/4 Flooring
33.	50320	Flange Nut – Shoe / Body (2 ea.)
34.	50125	Shoe – Angled

- 35. 50126 Screws – Valve Housing / Body (4) W/ 4 Washers (Ref. 44)
- 36. 50330 Piston / Driver Blade & O-Ring Assembly
- 37. 50134 Spring Pin – Constant Force Spring / Spools
- 38. 50415 Knurled Pusher Pull
- 39. 50140 Safety Stem
- 40. 50142 Cover – Safety
- 41. 50152 Main Valve Assembly & O-Rings
- 42. 50177 Screw – Face Shoe
- 43. 50154 Screws – Magazine / Retainer Bracket (3 ea.)
- 44. 50155 Washers – Valve Housing Screws (4 ea.)
- 45. 50161 Spring – Safety
- 46. 50162 Valve Housing Assembly
- 47. 50163 Ram Head Assembly W/Cap & Screw (Ref. 52 & 54)
- 48. 50113 Face Shoe
- 49. 50164 Screws – Guide / Magazine (2 ea.)
- 50. 2503 Screws – Shoe / Magazine / Cylinder Exhaust Valve (4 ea.)
- 51. 2600 Screws – Shoe Base (4 ea.)
- 52. 9005 Screw – Ram Head / Main Valve
- 53. 50281 Hex Adapter –3/8 NPT (Female) x 3/8 NPT (Male)
- 54. 40030 Ram Cap – Rubber

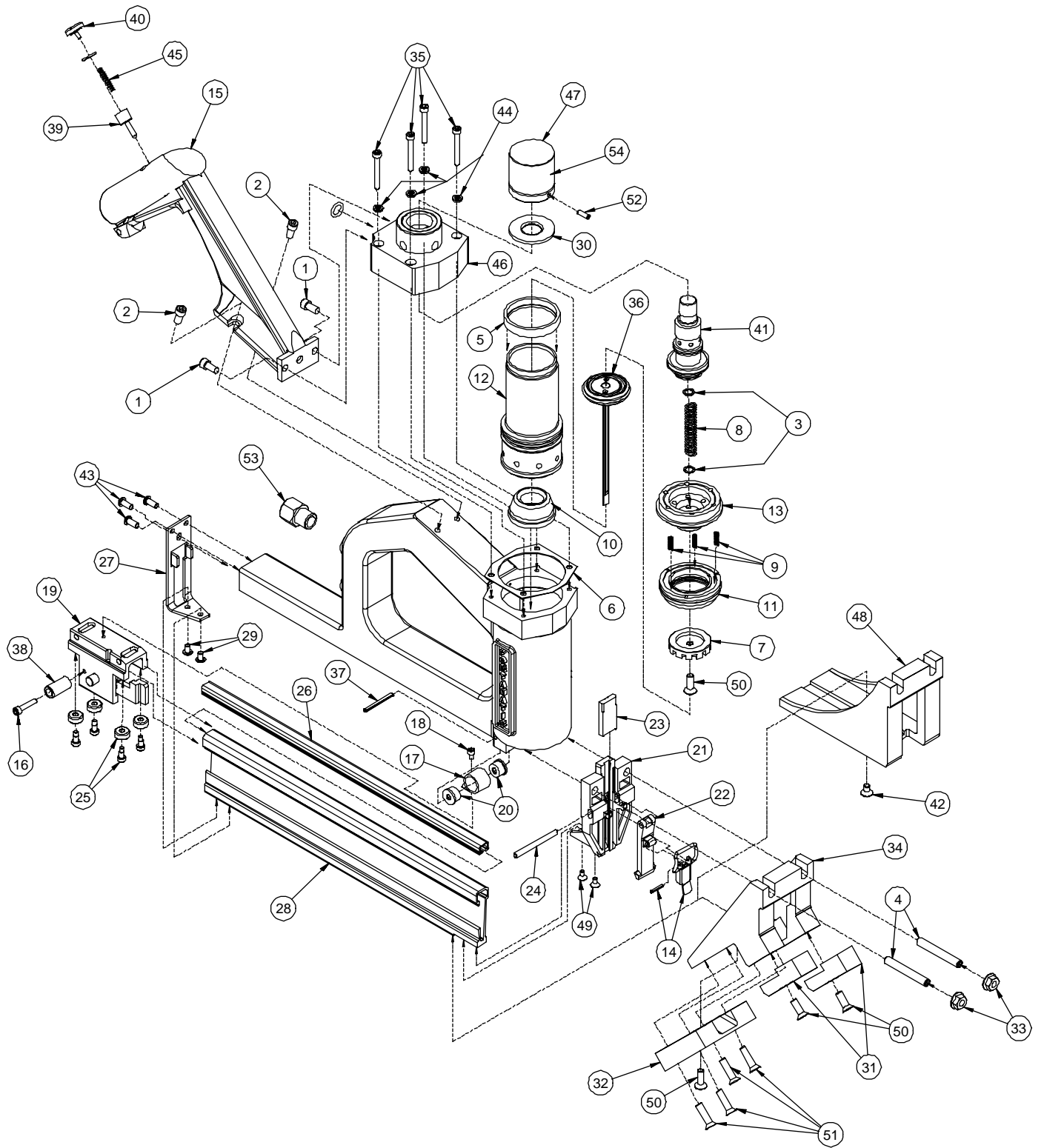

**421 PORTAMATIC®
TROUBLE SHOOTING**

PROBLEM OR QUESTION	CAUSE	CORRECTIVE ACTION
Nailer is Jamming	More than one Nail trying to get into chamber.	Check Rail (Ref. #26) for wear on the end. If worn, turn rail around to use other end in Guide or replace the rail. Make sure pusher provides positive pushing force on the nail clip to prevent nails from turning.
Nailer is not always firing a nail	Obstruction keeping the nail clip from advancing.	Clear obstruction, trash, bent or twisted nails, etc. Make sure Pusher provides positive pushing force on the Nail clip to prevent Nails from turning
Air is escaping	Damaged or worn seal.	Determine location of air escaping. Replace appropriate seal.
	Oil has been used causing O-Rings to swell which can restrict movement of piston or other component that must seal.	Clean internal components. Check for damaged seals or O-Rings. Replace damaged seal or O-Ring. Grease as specified in Owner's Manual.
Nailer is shooting two nails.	End of Rail is worn	Turn Rail (Ref. #26) around to use other end in Guide if this has not been previously done. If Rail has already been turned previously, replace Rail.
	Screws holding Magazine (Ref. #28) may be loose preventing Rail (Ref. #26) from being held properly in place.	Tighten Screws (Ref. #49, #29) that secure the Magazine (Ref. #28) to the Guide (Ref. #21) and the back Magazine Retainer Bracket (Ref. #27).
Nails are not being counter sunk into wood and are left sticking out of wood.	Not driving Nails into the tongue area	Always drive Nails into the tongue area, not the groove.
	Tip of Driver Blade (Ref. #36) broken	Check Driver Blade (Ref. #36) and replace if tip is broken.
	Air pressure too low	Set air pressure to 90-95 PSI
	Using air compressor that is too small	Follow recommendations in the Owner's Manual relative to size and volume of air compressor
	Using an air line that is too small	Always use 3/8" ID air line.
	The Piston Cushion (Ref. #10) could be damaged preventing the Piston (Ref. #36) from completing full stroke.	Check Piston Cushion (Ref. #10) and replace if needed.
Nailer does not fire when trigger is pulled.	This is a safety feature	The Nailer is not supposed to fire when the Trigger is pulled. In order to fire the Nailer, the Trigger must be pulled and the Ram Head (Ref. #47) struck with the hammer, in that order.

Ram is stuck in down position	Driver Blade (Ref. #36) could be bent	Check and replace if needed.
	Oil could have been used in the tool	Clean, replace O-Rings and grease as recommended in the Owner's Manual
	Cylinder Cushion Ring (Ref. #5) could be loose or damaged	Check Cylinder Cushion Ring (Ref. #5) and replace if loose or damaged
Tool partially fires when air hose is connected	Main Valve (Ref. #41) is not seating in Valve Housing (Ref. #46).	Check the Return Spring (Ref. #8) under the Main Valve (Ref. #41) to make sure it is not damaged and that the Return Spring Washers (Ref. #3) are not damaged. Replace if needed. Check for smoothness and free movement of the Main Valve (Ref. #41) in the Valve Housing (Ref. #46). If too tight, replace the O-Rings on the Main Valve.
	O-Rings on the Discharge Valve (Ref. #11) may be damaged.	Check and replace if needed.
	Discharge Valve Springs (Ref. #9) not aligned	Check and re-align if needed.
	Cylinder Exhaust Valve Screw (Ref. #50) may be loose.	Check and tighten if needed. Use LOCTITE® 242 (Blue) on screw.
Nailer partially fires when trigger is pulled and before Ram is struck	Main Valve Lip Seal (Ref. #41) is not sealing	Check Lip Seal. If damaged, replace Main Valve (Ref. #41).