

# SEARS

## OWNERS MANUAL

MODEL NO.  
315.11690

**CAUTION:**  
Read Rules for  
Safe Operation  
and Instructions  
Carefully

SAVE THIS  
MANUAL FOR  
FUTURE REFERENCE



# CRAFTSMAN<sup>®</sup>

## SANDER

DUAL MOTION  
DOUBLE INSULATED

Introduction  
Operation  
Repair Parts



Designed exclusively for and sold only by  
SEARS, ROEBUCK AND CO., Dept. 698/731A, Sears Tower, Chicago, IL 60684

## FULL ONE YEAR WARRANTY ON CRAFTSMAN SANDER

If this Craftsman Sander fails to give complete satisfaction within one year from date of purchase, **RETURN IT TO THE NEAREST SEARS STORE THROUGHOUT THE UNITED STATES** and Sears will replace it, free of charge.

If this sander is used for commercial or rental purposes this warranty applies for only 90 days from the date of purchase.

This warranty gives you specific legal rights, and you may also have other rights which vary from state to state.

SEARS, ROEBUCK AND CO.  
DEPT. 698/731A  
SEARS TOWER  
CHICAGO, IL 60684

## INTRODUCTION

**DOUBLE INSULATION** is a concept in safety, in electric power tools, which eliminates the need for the usual three wire grounded power cord and grounded supply system. Wherever there is electric current in the tool there are two complete sets of insulation to protect the user. All exposed metal parts are isolated from the internal metal motor components with protecting insulation.

Your sander is suitable for coarse, medium and fine sanding of wood, metals, and plastics. It will produce a fine scratch free finish when used with or against the grain and is designed for sanding flush to corners.

**IMPORTANT** — Servicing of a tool with double insulation requires extreme care and knowledge of the system and should be performed only by a qualified service technician. For service we suggest you return the tool to your nearest Sears Store for repair. Always use original factory replacement parts when servicing.

The dual motion feature with which your sander is equipped is ideal for any sanding operation where a pad sander is required. Orbital motion is ideal for fast cutting action when removing old finishes, smoothing rough wood, cutting stock down to required dimensions or for finishing surface to be painted. Straight line is best for fine finish sanding on work to be stained or varnished.

### RULES FOR SAFE OPERATION

**WARNING** — DO NOT ATTEMPT TO OPERATE UNTIL YOU HAVE READ THOROUGHLY AND UNDERSTAND COMPLETELY ALL INSTRUCTIONS, RULES, ETC. CONTAINED IN THIS MANUAL. FAILURE TO COMPLY CAN RESULT IN ACCIDENTS INVOLVING FIRE, ELECTRIC SHOCK, OR SERIOUS PERSONAL INJURY. SAVE OWNERS MANUAL AND REVIEW FREQUENTLY FOR CONTINUING SAFE OPERATION, AND INSTRUCTING POSSIBLE THIRD-PARTY USER.

#### READ ALL INSTRUCTIONS

1. **KNOW YOUR POWER TOOL** — Read owner's manual carefully. Learn its applications and limitations as well as the specific potential hazards peculiar to this tool.
2. **GUARD AGAINST ELECTRICAL SHOCK BY PREVENTING BODY CONTACT WITH GROUNDED SURFACES.** For example: Pipes, radiators, ranges, refrigerator enclosures.
3. **KEEP GUARDS IN PLACE** and in working order.
4. **KEEP WORK AREA CLEAN.** Cluttered areas and benches invite accidents.
5. **AVOID DANGEROUS ENVIRONMENT.** Don't use power tool in damp or wet locations or expose to rain. Keep work area well lit.
6. **KEEP CHILDREN AWAY.** All visitors should be kept safe distance from work area. Do not let visitors contact tool or extension cord.
7. **STORE IDLE TOOLS.** When not in use, tools should be stored in dry, high or locked-up place — out of reach of children.
8. **DON'T FORCE TOOL.** It will do the job better and safer at the rate for which it was designed.
9. **USE RIGHT TOOL.** Don't force small tool or attachment to do the job of a heavy duty tool. Don't use tool for purpose not intended - for example - Don't use a circular saw for cutting tree limbs or logs.
10. **WEAR PROPER APPAREL.** No loose clothing or jewelry to get caught in moving parts. Rubber gloves and footwear are recommended when working outdoors. Also, wear protective hair covering to contain long hair.

## **RULES FOR SAFE OPERATION (Continued)**

11. **USE SAFETY GLASSES** with all tools. Also face or dust mask if cutting operation is dusty.
12. **DON'T ABUSE CORD.** Never carry tool by cord or yank it to disconnect from receptacle. Keep cord from heat, oil and sharp edges.
13. **SECURE WORK.** Use clamps or a vise to hold work. It's safer than using your hand and it frees both hands to operate tool.
14. **DON'T OVERREACH.** Keep proper footing and balance at all times.
15. **MAINTAIN TOOLS WITH CARE.** Keep tools sharp at all times, and clean for best and safest performance. Follow instructions for lubricating and changing accessories.
16. **DISCONNECT TOOLS.** When not in use, before servicing, or when changing attachments, blades, bits, cutters, etc., all tools should be disconnected.
17. **REMOVE ADJUSTING KEYS AND WRENCHES.** Form habit of checking to see that keys and adjusting wrenches are removed from tool before turning it on.
18. **AVOID ACCIDENTAL STARTING.** Don't carry plugged-in tools with finger on switch. Be sure switch is off when plugging in.
19. **OUTDOOR USE EXTENSION CORDS.** When tool is used outdoors, use only extension cords suitable for use outdoors. Outdoor approved cords are marked with the suffix W-A, for example — SJTW-A or SJOW-A.
20. **NEVER THIS USE THIS OR ANY POWER SANDER FOR WET SANDING.** Failure to comply can result in electrical shock causing serious injury or worse.
21. **KEEP HANDS AWAY FROM SANDING AREA.**
22. **NEVER USE IN AN EXPLOSIVE ATMOSPHERE.** Normal sparking of the motor could ignite fumes.
23. **INSPECT TOOL CORDS PERIODICALLY** and if damaged, have repaired at your nearest Sears Repair Center.
24. **INSPECT EXTENSION CORDS PERIODICALLY** and replace if damaged.
25. **KEEP HANDLES DRY, CLEAN, AND FREE FROM OIL AND GREASE.** Always use a clean cloth when cleaning. Never use brake fluid, gasoline, or any strong solvents to clean your tool.
26. **STAY ALERT.** Watch what you are doing and use common sense. Do not operate tool when you are tired.
27. **CHECK DAMAGED PARTS.** Before further use of the tool, a guard or other part that is damaged should be carefully checked to determine that it will operate properly and perform its intended function. Check for alignment of moving parts, binding of moving parts, breakage of parts, mounting, and any other conditions that may affect its operation. A guard or other part that is damaged should be properly repaired or replaced by an authorized service center unless indicated elsewhere in this instruction manual.
28. **DO NOT USE TOOL IF SWITCH DOES NOT TURN IT ON AND OFF.** Have defective switches replaced by authorized service center.
29. Inspect for and remove all nails from lumber before sanding.
30. **DRUGS, ALCOHOL, MEDICATION.** Do not operate tool while under the influence of drugs, alcohol, or any medication.
31. **SAVE THESE INSTRUCTIONS.**

### **CAUTION**



The operation of any sander can result in foreign objects being thrown into the eyes, which can result in severe eye damage. Always wear safety glasses or eye shields before commencing power tool operation. We recommend Wide Vision Safety Mask for use over spectacles, or standard safety glasses. . . . available at Sears Catalog Order or Retail Stores.

# OPERATION

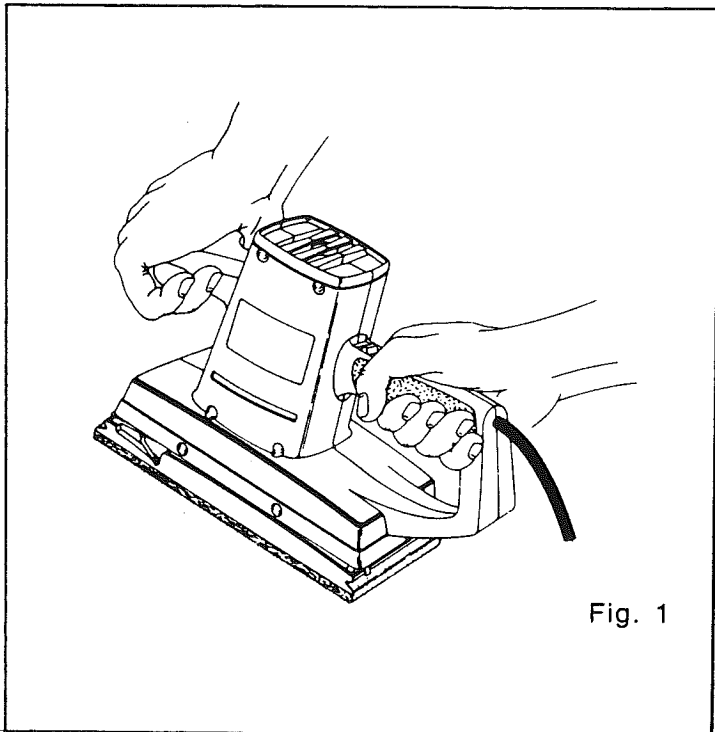

Fig. 1

For ease of operation your sander has a front handle and a rear handle. These handles allow two-hand operation which aid in maintaining control and keeping sanding area level with workpiece.

## SANDPAPER SELECTION

Selecting the correct size and type sandpaper is an extremely important step in achieving a high quality sanded finish. Aluminum oxide, silicone carbide, and other synthetic abrasives are best for power sanding. Other natural abrasives, such as flint and garnet sandpaper are too soft for economical use in power sanding. In general, coarse grit will remove the most material and finer grit will produce the best finish in all sanding operations. The condition of the surface to be sanded will determine which grit sandpaper will do the job. If the surface is rough, start with a coarse grit paper sanding until surface is uniform. Medium grit paper may then be used to remove scratches left by the coarser paper and finer grit paper used for finishing of the surface. Always continue sanding with each grit paper until surface is uniform.

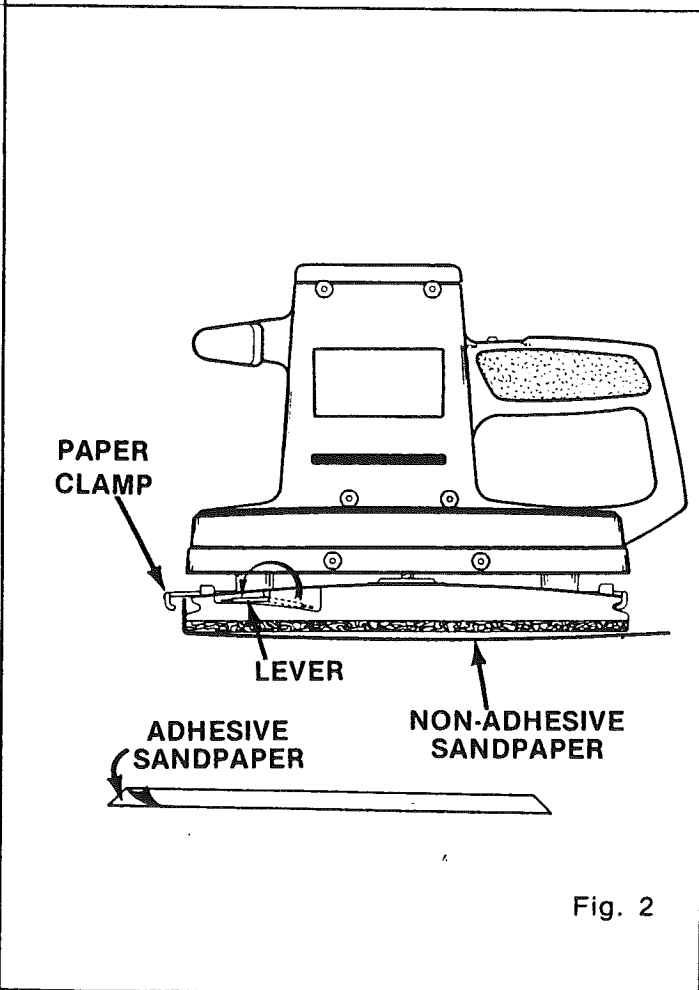

Fig. 2

## INSTALLING ADHESIVE SANDPAPER

1. Unplug the sander. **WARNING: FAILURE TO UNPLUG THE SANDER COULD RESULT IN ACCIDENTAL STARTING CAUSING INJURY.**
2. If replacing sandpaper, remove old sandpaper by peeling it off cushion. If removing regular sandpaper, release lever on paper clamp by pulling it out and rotating toward the end of cushion as shown in Figure 2.
3. Peel adhesive backing from new 1/2 sheet sandpaper. See Figure 2.
4. Position sandpaper into place, then carefully press sticky side of sandpaper on cushion.

## INSTALLING NON-ADHESIVE SANDPAPER

1. Unplug the sander. **WARNING: FAILURE TO UNPLUG THE SANDER COULD RESULT IN ACCIDENTAL STARTING CAUSING INJURY.**
2. Release lever on paper clamp by pulling out and rotating toward end of cushion as shown in Figure 2.
3. Place 1/2 sheet sandpaper under paper clamp. See Figure 2.
4. Secure sandpaper by locking lever.
5. Release lever on opposite end of sander.
6. Wrap sandpaper around cushion.
7. Place sandpaper under paper clamp on opposite end of sander and secure by locking lever.

# OPERATION (CONTINUED)

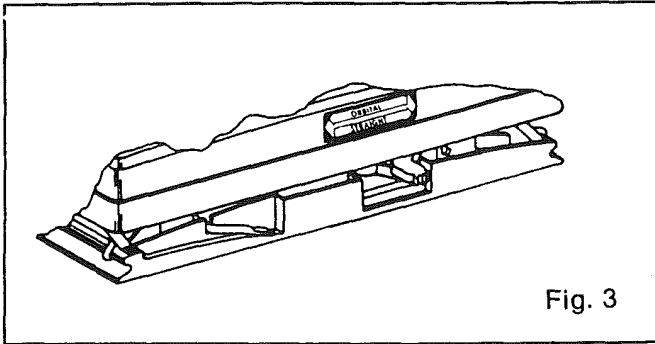

Fig. 3

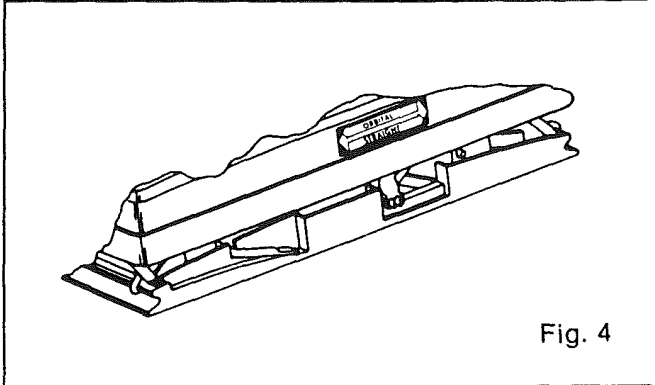

Fig. 4

## MOTION SELECTIONS

The dual motion feature of your sander provides required motion for any sanding application. The orbital motion provides fast cutting action when you need to remove old finishes, smooth rough wood, cut stock down to required dimensions, or sand surfaces to be painted. Straight line motion provides fine finish sanding on work to be stained or varnished. **WARNING: NEVER CHANGE THE MOTION SETTING WHILE THE SANDER IS "ON".**

## SETTING MOTION

1. Unplug the sander. **WARNING: FAILURE TO UNPLUG SANDER COULD RESULT IN ACCIDENTAL STARTING CAUSING INJURY.**
2. DO NOT CHANGE MOTION SETTING WHILE SANDER IS OPERATING.
3. For straight line motion slide lever forward as shown in Fig. 3.
4. For orbital motion slide lever backwards as shown in Fig. 4.

**NOTE:** There is a decal on the side of your sander which indicates correct motion settings.

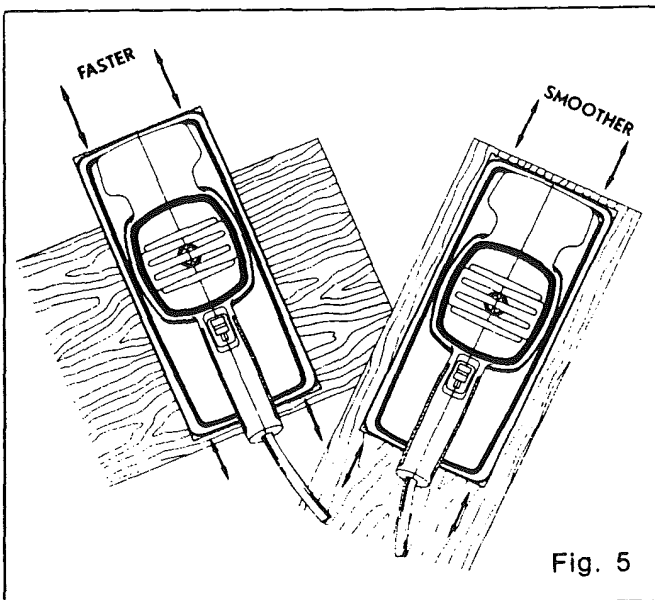

Fig. 5

**WARNING: DO NOT WEAR LOOSE CLOTHING OR JEWELRY WHEN OPERATING SANDER. THEY COULD GET CAUGHT IN MOVING PARTS CAUSING INJURY. KEEP HEAD AWAY FROM SANDER AND SANDING AREA. HAIR COULD BE DRAWN INTO SANDER AND FOREIGN OBJECTS COULD GET THROWN AWAY FROM SANDER CAUSING INJURY.**

While holding your sander firmly in front of and clearly away from you, with the sanding surface clear of any foreign material, slide switch starting sanding action. Place the sander gently onto the work and move slowly using forward and backward strokes. **DO NOT FORCE.** The weight of the unit supplies adequate pressure, so let the sanding sheet and sander do the work. Applying additional pressure only slows the motor, rapidly wears sandpaper and greatly reduces speed. Excessive pressure will overload the motor causing possible damage from motor overheating and can result in inferior work as any finish or resin on wood may soften from the frictional heat. Sanding with the grain of wood gives the smoothest finish while sanding against the grain results in faster sanding. (See Fig. 5.) The sander can move the length of the entire surface, however, do not allow sanding on one spot too long as its rapid action may remove too much material making the surface uneven. Always remove sander from workpiece before sliding switch into "Off" position stopping sanding action.

Flush sanding can be performed with three of the four sides of your sander. Every side but the rear of the sander can be used when sanding in corners. Always remove sander from workpiece before sliding into "Off" position stopping sanding action.

# OPERATION (Cont.)

## GENERAL

### WHEN SERVING USE ONLY IDENTICAL REPLACEMENT PARTS

Only the parts shown on page seven are intended to be repaired or replaced by the customer. All other parts represent an important part of the double insulated system and are not intended to be replaced.

Avoid using solvents when cleaning plastic parts. Most plastics are susceptible to various types of commercial solvents and may be damaged by their use. Use clean cloths to remove dirt, carbon dust, etc. **WARNING: DO NOT AT ANY TIME LET BRAKE FLUIDS, GASOLINE, PENETRATING OILS, ETC. COME IN CONTACT WITH PLASTIC PARTS. THEY CONTAIN CHEMICALS THAT CAN DAMAGE AND/OR DESTROY PLASTIC.**

When electric tools are used on fiberglass boats, sports cars, wallboard, spackling compounds, or plaster, it has been found that they are subject to accelerated wear and possible premature failure, as the chips and grindings are highly abrasive to bearings, brushes, commutator, etc. Consequently, it is not recommended that this tool be used for extended work on any fiberglass material, wallboard, spackling compounds, or plaster. During any use on these materials it is extremely important that the tool is cleaned frequently by blowing with an air jet. **ALWAYS WEAR SAFETY GLASSES OR EYE SHIELDS BEFORE BEGINNING THIS OPERATION.**

---

### EXTENSION CORDS

The use of any extension cord will cause some loss of power. To keep the loss to a minimum and to prevent tool overheating, use minimum 16 A.W.G. wire size for extension cord lengths from 25 to 100 feet. When tool is used outdoors, use only extension cords suitable for outdoor use and so marked. Extension

cords are available at Sears Catalog Order or Retail Stores. **WARNING: CHECK EXTENSION CORDS BEFORE EACH USE. IF DAMAGED, REPLACE IMMEDIATELY. NEVER USE TOOL WITH A DAMAGED CORD SINCE TOUCHING THE DAMAGED AREA COULD CAUSE ELECTRICAL SHOCK RESULTING IN SERIOUS INJURY.**

## NOTES

---

---

---

---

---

---

---

---

---

---

---

---

---

---

---

---

---

---

---

---

---

---

---

---

# CRAFTSMAN SANDER — MODEL NUMBER 315.11690

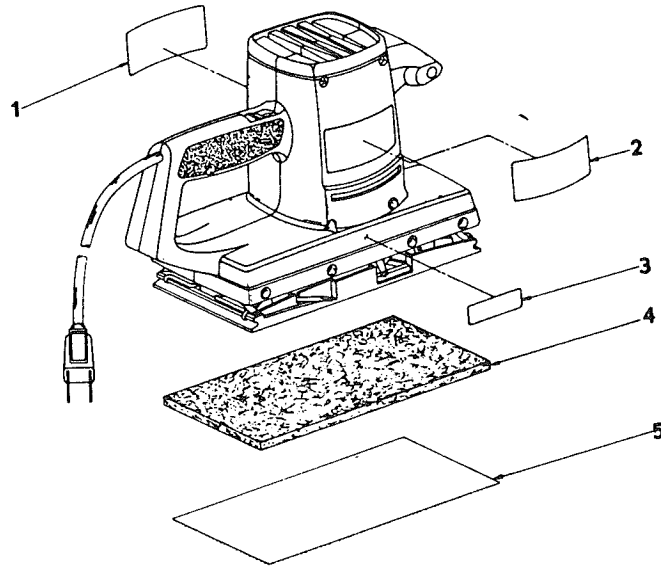

SEE BACK PAGE FOR PARTS ORDERING INSTRUCTIONS

## PARTS LIST

Key No.	Part Number	Description	Quan.
1	610515-001	Logo Plate.....	1
2	612007-001	Data Plate.....	1
3	607119-001	Motion Setting Decal.....	1
4	989522-001	Cushion.....	1
5	***	Sandpaper	
	620263-963	Owner's Manual	

\*\*\*Complete Assortment Available At Your Nearest Catalog Order Or Retail Store.

THE FOLLOWING RECOMMENDED ACCESSORIES ARE CURRENT AND WERE AVAILABLE AT THE TIME THIS MANUAL WAS PRINTED.

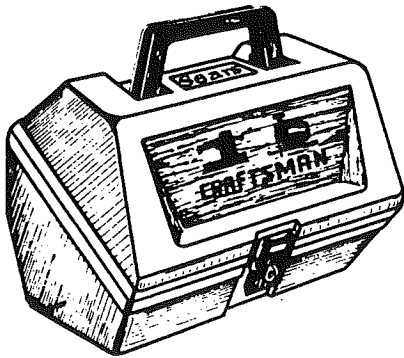

**CARRYING CASE**  
Cat. No. 9 1474

### ADHESIVE PAPER BACKED SANDING SHEETS

Cat. No. 9 25351 Fine  
Cat. No. 9 25352 Medium  
Cat. No. 9 25353 Coarse



**CORD LOCK**  
Cat. No. 9 2595

### ASSORTED SANDING SHEETS

Cat. No. 9 25315 Fine  
Cat. No. 9 25316 Medium  
Cat. No. 9 25317 Coarse  
Cat. No. 9 25318 X-Coarse

### SHEETS IDEAL FOR ORBITAL SANDING

Cat. No. 9 25335 Fine  
Cat. No. 9 25336 Medium  
Cat. No. 9 25337 Coarse

**CAUTION:** The use of attachments or accessories not listed above might be hazardous.

# SEARS

OWNERS  
MANUAL

SERVICE

MODEL NO.  
315.11690

HOW TO ORDER  
REPAIR PARTS

# CRAFTSMAN<sup>®</sup>

## SANDER DUAL MOTION DOUBLE INSULATED

Now that you have purchased your Sander, should a need ever exist for repair parts or service, simply contact any Sears Service Center and most Sears, Roebuck and Co. stores. Be sure to provide all pertinent facts when you call or visit.

The model number of your Sander will be found on the plate attached to the housing.

WHEN ORDERING REPAIR PARTS, ALWAYS GIVE THE FOLLOWING INFORMATION:

- PART NUMBER
- PART DESCRIPTION
- MODEL NUMBER  
315.11690
- NAME OF ITEM  
Sander

All parts listed may be ordered from any Sears Service Center and most Sears stores.

If the parts you need are not stocked locally, your order will be electronically transmitted to a Sears Repair Parts Distribution Center for handling.